

INJ. PUMP CALIBRATION DATA

ENGINE MODEL 3AB1

BOSCH No. 9 400 610 079 1/4
 DKKC No. 101342 - 0160
 Date : 28, Oct. 1988 [0]
 Company : ISUZU
 No. 5156004881

B - 1

101342 - 0180 2/4

Injection pump : PES3A Governor : EP/RSV Timing device :
 101034-9030 105410-1650

1. Test Conditions :

Pump rotation : Counter clockwise viewed from drive side

Nozzle & Nozzle Holder Ass'y : 105780-0000 Nozzle Holder : 105780-2080
 (BOSCH Type No. DN12SD12T) (BOSCH Type No. EF8511/9A)
 Nozzle opening pressure : 175 kg/cm² Transfer pump pressure : 1.6 kg/cm²
 Injection pipe :
 Inner Dia. 2 mm x Outer Dia. 6 mm - Length 600 mm

Test Oil : ISO4113 or SAE Standard Test Oil (SAE J967d) Oil Temp. : 40 ± 5°C

Overflow valve opening pressure : - kg/cm²

2. Injection Timing :

Pre-stroke : No. 1 Plunger 1.95 ± 0.05 mm

Note : Adjust with control rod position of mm

Injection order : 1 - 3 - 2 - 1

(interval : 120° ± 30')

Plungers are numbered from the Drive side.

Tappet clearance : Bolt adjustment type ; More than 0.3 mm for all cylinders.
 ; Shim adjustment type ; Manually rotate the camshaft 2 - 3 times and confirm that it rotates smoothly.

4. Injection Quantity :

Adjusting Point	Rod Position (mm)	Pump Speed (r.p.m.)	Injection Q'ty (cc/1000 strokes)	Max. var bet. cyl (%)	Fixed	Remarks
A	11.7	1,200	41.5 ~ 43.1	± 2	Rack	Basic
H	Approx. 7.3	360	4.8 ~ 6.8	± 14	Rack	
A	11.7	1,200	41.5 ~ 43.1	-	Lever	Basic

5. Timing Advance Specification :

Pump Speed (r.p.m.)	Advance Angle (deg)	Start				
		0				

3. GOVERNOR ADJUSTMENT

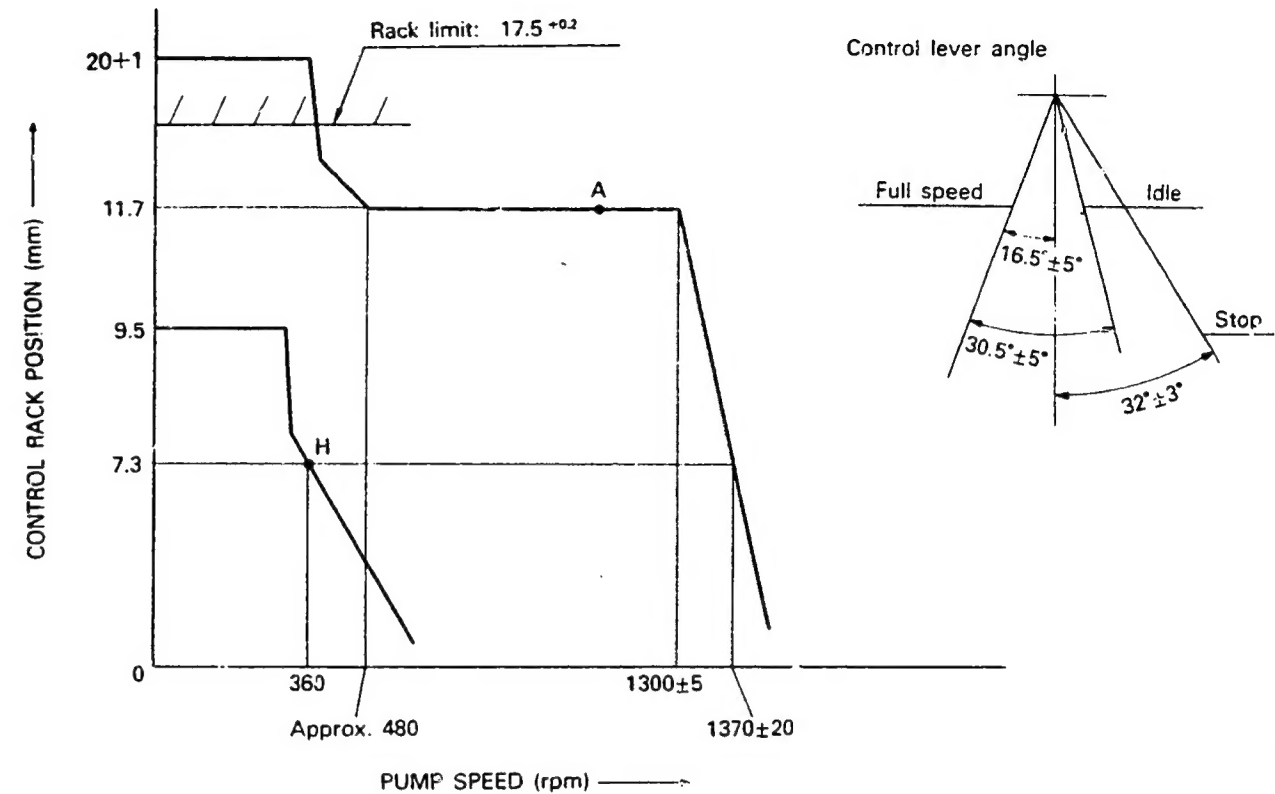

Note

- Before adjustment, remove the idling sub spring and the torque control spring.
- Move the control lever fully in the stop direction, and set the minimum-speed stopper bolt so that the control rack position is 0.5 - 1.0 mm.

Adjustment

Item	Pump Speed (rpm)	Rack Position (mm)	Remarks
Full-load Adjustment (Temporary)	1295 ~ 1305	11.7	• Adjust using screw 1
	1200	11.7	• Adjust using screw 2
Torque Control Spring Adjustment			• Adjust using spring capsule 1 • Confirm • Confirm • Confirm the torque control stroke is mm.

Item	Pump Speed (rpm)	Rack Position (mm)	Remarks
Idling Adjustment	0	9.5	<ul style="list-style-type: none"> • Fix the control lever • Adjust using spring capsule 2 • Confirm
	360	7.3	
	—	—	
Maximum-speed Adjustment	1295 ~ 1305	11.7	<ul style="list-style-type: none"> • Adjust using screw ① • Confirm speed droop • Confirm • Confirm
	1350 ~ 1390	7.3	
	—	—	
Full-load Adjustment (Install the cover on governor cover)	1200	11.7	• Adjust using screw ①
Control Lever Angle Measurement	<ul style="list-style-type: none"> • Measure the control lever angle at the "idling" and "full" positions • When the control lever is depressed toward the "full" position, replace the shifter's shim with a thicker one. • When the control lever is depressed toward the "idling" position, replace the shifter's shim with a thinner one. 		
Rack Limiter Adjustment	0	17.5 ^{+0.2}	• Adjust using screw

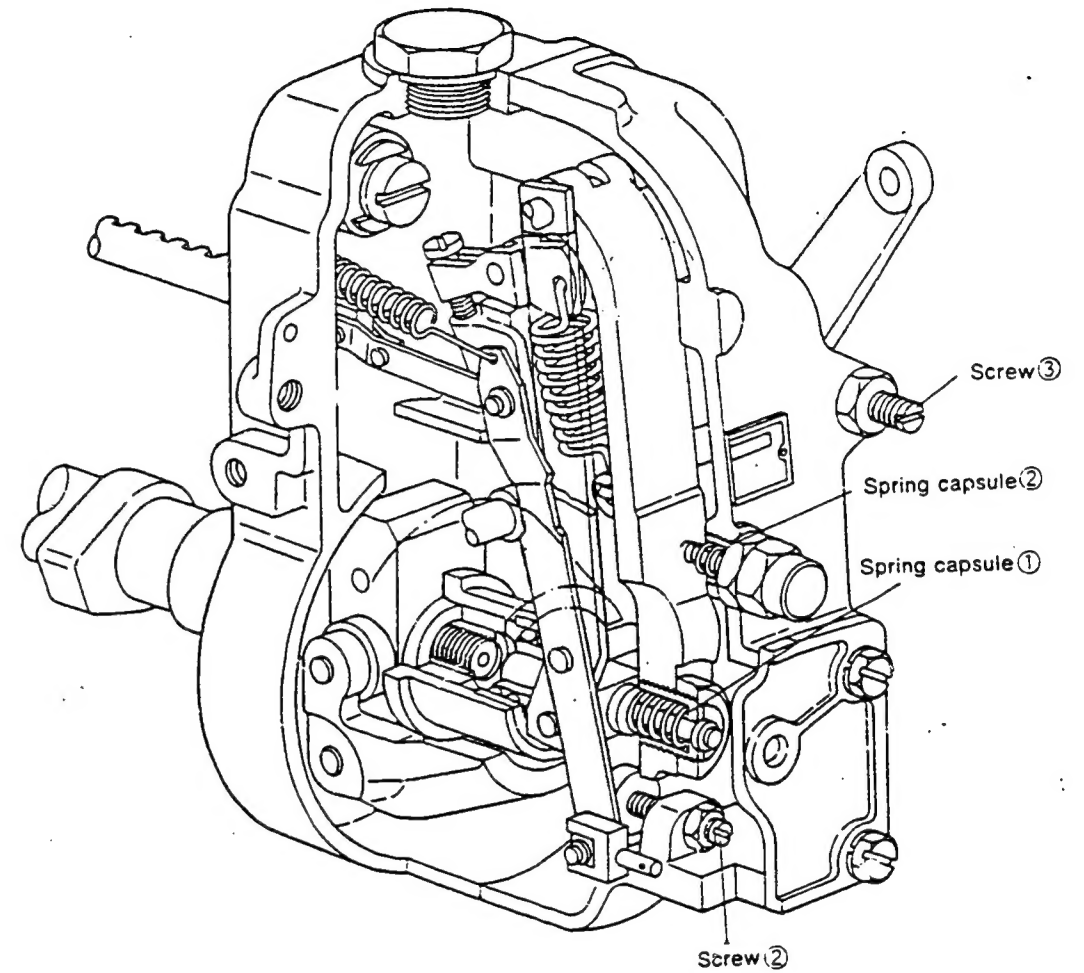

INJ. PUMP CALIBRATION DATA

ENGINE MODEL C240

BOSCH No. 9 400 610 054 1/4
 DKKC No. 101431 - 0790
 Date : 26, Oct. 1988
 Company : ISUZU
 No. 5156011430

Injection pump : PES4A Governor : EP/MZ Timing device : EP/SCD
 101043-9160 105520-3120 105521-0370

1. Test Conditions :

Pump rotation : Counter clockwiseviewed from drive side

Nozzle & Nozzle Holder Ass'y : 105780-0000 Nozzle Holder : 105780-2080
 (BOSCH Type No. DN12SD12T) (BOSCH Type No. EF8511/9A)
 Nozzle opening pressure : 175 kg/cm² Transfer pump pressure : 1.6 kg/cm²

Injection pipe :
 Inner Dia. 2 mm x Outer Dia. 6 mm — Length 600 mm

Test Oil : ISO4113 or SAE Standard Test Oil (SAE J967d) Oil Temp. : 40°C

Overflow valve opening pressure : kg/cm²

2. Injection Timing :

Pre-stroke : No. 1 Plunger 2.25 ± 0.05 mm

Note : Adjust with control rod position of mm

Injection order : 1 - 3 - 4 - 2 (interval : 90° ± 30')

Plungers are numbered from the Drive side.

Tappet clearance : Bolt adjustment type ; More than 0.3 mm for all cylinders.
 ; Shim adjustment type ; Manually rotate the camshaft 2 - 3 times and confirm that it rotates smoothly.

4. Injection Quantity :

Adjusting Point	Rod Position (mm)	Pump Speed (r.p.m.)	Injection Q'ty (cc/1000 strokes)	Max. var bet. cyl (%)	Fixed	Remarks
	12.7	1,000	35.8 - 37.8	± 2.5	Rod	Basic
	Approx. 8.4	350	5.9 - 8.1	± 14	Rod	

5. Timing Advance Specification :

Pump Speed (r.p.m)	500 ± 50	800	1,050	1,500	1,750		
Advance Angle (deg)	Start 0	1 ± 0.5	2 +0.7 -0.8	4.5 +0.4 -0.6	6 ± 0.5		

3. GOVERNOR ADJUSTMENT

B - 3

101431 - 0790 2/4

(1) Pneumatic Governor

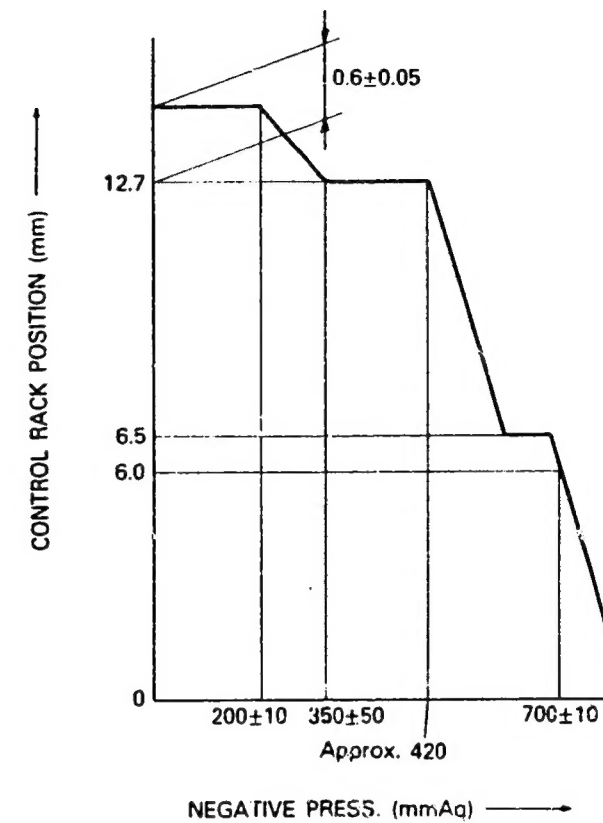

■ Air Tightness Test

1. Increase the pressure of the pneumatic governor's negative pressure chamber to 500 mmAq at a pump speed of 500 rpm and a control rack position of Approx. 13.3 mm.
2. Then, confirm that it takes 10 seconds or more for the negative pressure to fall from 500 mmAq to 480 mmAq.

■ Adjustment

Pneumatic Governor (Pump Speed: 500 rpm)

Item	Negative Press. (mmAq)	Rack Position (mm)	Remarks
Smoke Set Screw Adjustment	0	Approx. 13.3	• Adjust using spring capsule 1.
Torque Control Adjustment			
1 Start of torque control spring movement	190 - 210	Approx. 13.3	• Adjust thickness of shim 1.
2 End of torque control spring movement	300 - 400	12.7	• Adjust thickness of shim 2.
3 Confirm	—	—	
4 Confirm torque control stroke	—	—	• Inspection: 0.55 - 0.65 mm



DIESEL KIKI CO. LTD. 3-6-7 SHIBUYA, SHIBUYA-KU, TOKYO 150, JAPAN
 Service Department Tel (03) 400-1551 Fax (03) 499-4115

B - 4

Item	Negative Press. (mmAq)	Rack Position (mm)	Remarks
High-speed Control Adjustment	Approx. 420	12.7	<ul style="list-style-type: none"> • Adjust thickness of shim 3.
Idling Adjustment	— 690 ~ 710	6.5 6.0	<ul style="list-style-type: none"> • Adjust using spring capsule 2. • Confirm

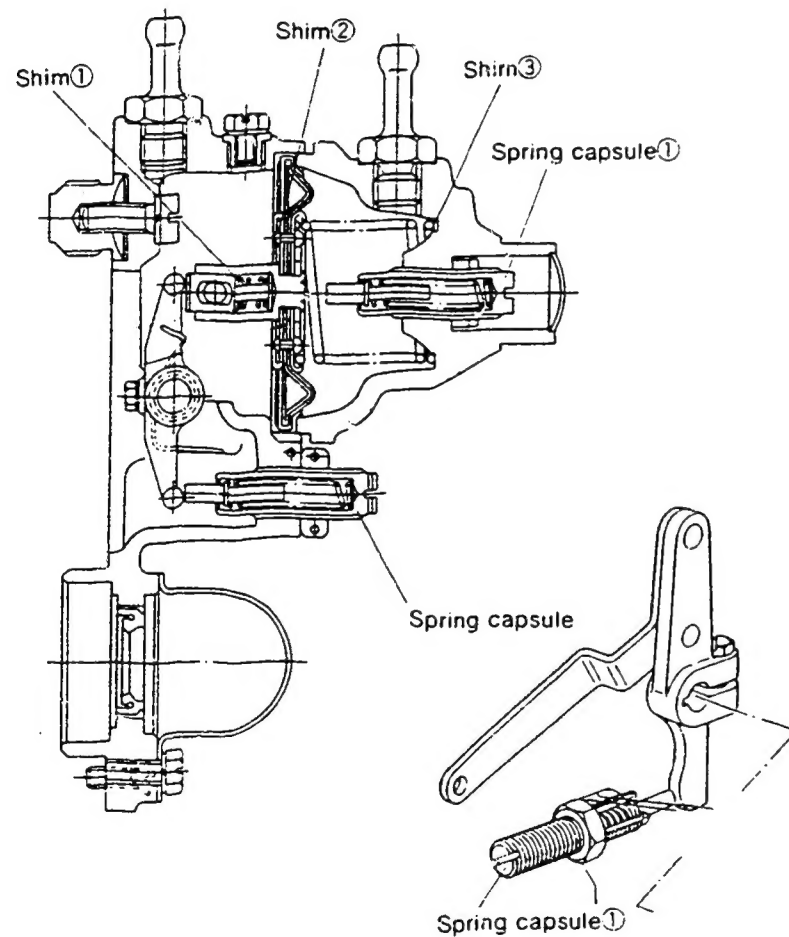

■ Final Adjustment

Smoke Setting			Fuel Injection Quantity Adjustment		
Pump Speed (rpm)	Negative Press. (mmAq)	Injection Q'ty (cc/1000st)	Pump Speed (rpm)	Negative Press. (mmAq)	Injection Q'ty (cc/1000st)
1000	—	35.8 ~ 37.8			

■ Timing Setting

At No. 1 plunger's beginning of injection position.

B.T.D.C.: 14°

INJ. PUMP CALIBRATION DATA

ENGINE MODEL C240

BOSCH No. 9 400 610 080 1/4
 DKKC No. 101432 - 0160
 Date : 28, Oct. 1988
 Company : ISUZU
 No. 5156010270

B - 5

101432 - 0160 2/4

Injection pump : PES4A Governor : EP/RSV Timing device :
 101043-9190 105410-5030

1. Test Conditions :

Pump rotation : Counter clockwise viewed from drive side

Nozzle & Nozzle Holder Ass'y : 105780-0000 Nozzle Holder : 105780-2060
 (BOSCH Type No. DN12SD12T) (BOSCH Type No. EF8511/9A)
 Nozzle opening pressure : 175 kg/cm² Transfer pump pressure : 1.6 kg/cm²
 Injection pipe :
 Inner Dia. 2 mm x Outer Dia. 6 mm - Length 600 mm

Test Oil : ISO4113 or SAE Standard Test Oil (SAE J967d) Oil Temp. : 40 ± 5°C

Overflow valve opening pressure : 1.6 kg/cm²

2. Injection Timing :

Pre-stroke : No. 1 Plunger 2.25 ± 0.05 mm

Note : Adjust with control rod position of mm

Injection order : 1 - 3 - 4 - 2 (interval : 90° ± 30')

Plungers are numbered from the Drive side.

Tappet clearance : Bolt adjustment type ; More than 0.3 mm for all cylinders.
 Shim adjustment type ; Manually rotate the camshaft 2 - 3 times and confirm that it rotates smoothly.

4. Injection Quantity :

Adjusting Point	Rod Position (mm)	Pump Speed (r.p.m.)	Injection Q'ty (cc/1000 strokes)	Max. var bet. cyl (%)	Fixed	Remarks
A	12	1,150	40 ~ 42	± 2.5	Rack	Basic
B	12	750	36 ~ 40	± 4	Rack	
C	Approx. 7.2	350	6.9 ~ 9.1	± 14	Rack	

5. Timing Advance Specification :

Pump Speed (r.p.m.)	Advance Angle (deg)						
	Start	0					

3. GOVERNOR ADJUSTMENT

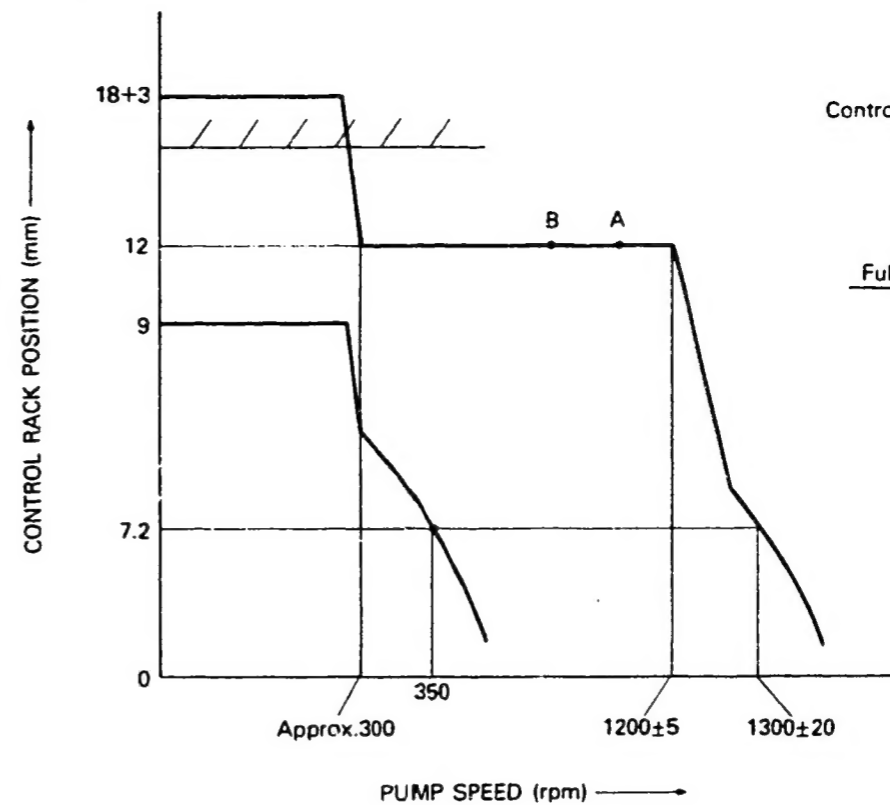

■ Note

- Before adjustment, remove the idling sub spring and the torque control spring.
- Move the control lever fully in the stop direction, and set the minimum-speed stopper bolt so that the control rack position is 0.5 - 1.0 mm.

■ Adjustment

Item	Pump Speed (rpm)	Rack Position (mm)	Remarks..
Full-load Adjustment (Temporary)	1195 ~ 1205	12.0	• Adjust using screw 1
	1150	12.0	• Adjust using screw 2
Torque Control Spring Adjustment			• Adjust using spring capsule 1 • Confirm • Confirm • Confirm the torque control stroke is mm.



DIESEL KIKI CO., LTD.
 Service Department

3-6-7 SHIBUYA, SHIBUYA-KU, TOKYO 150, JAPAN
 Tel (03) 400-1551 Fax (03) 499-4115

Item	Pump Speed (rpm)	Rack Position (mm)	Remarks
Idling Adjustment	0	9.0	<ul style="list-style-type: none"> • Fix the control lever • Adjust using spring capsule ② • Confirm
	350	7.2	
	—	—	
Maximum-speed Adjustment	1195 — 1205	12.0	<ul style="list-style-type: none"> • Adjust using screw ① • Confirm speed droop • Confirm • Confirm
	1280 — 1320	7.2	
	—	—	
Full-load Adjustment (Install the cover on governor cover)	1150	12.0	<ul style="list-style-type: none"> • Adjust using screw ③
Control Lever Angle Measurement	<ul style="list-style-type: none"> • Measure the control lever angle at the "idling" and "full" positions. • When the control lever is depressed toward the "full" position, replace the shifter's shim with a thicker one • When the control lever is depressed toward the "idling" position, replace the shifter's shim with a thinner one. 		
Rack Limiter Adjustment	0	17.5	<ul style="list-style-type: none"> • Adjust using screw

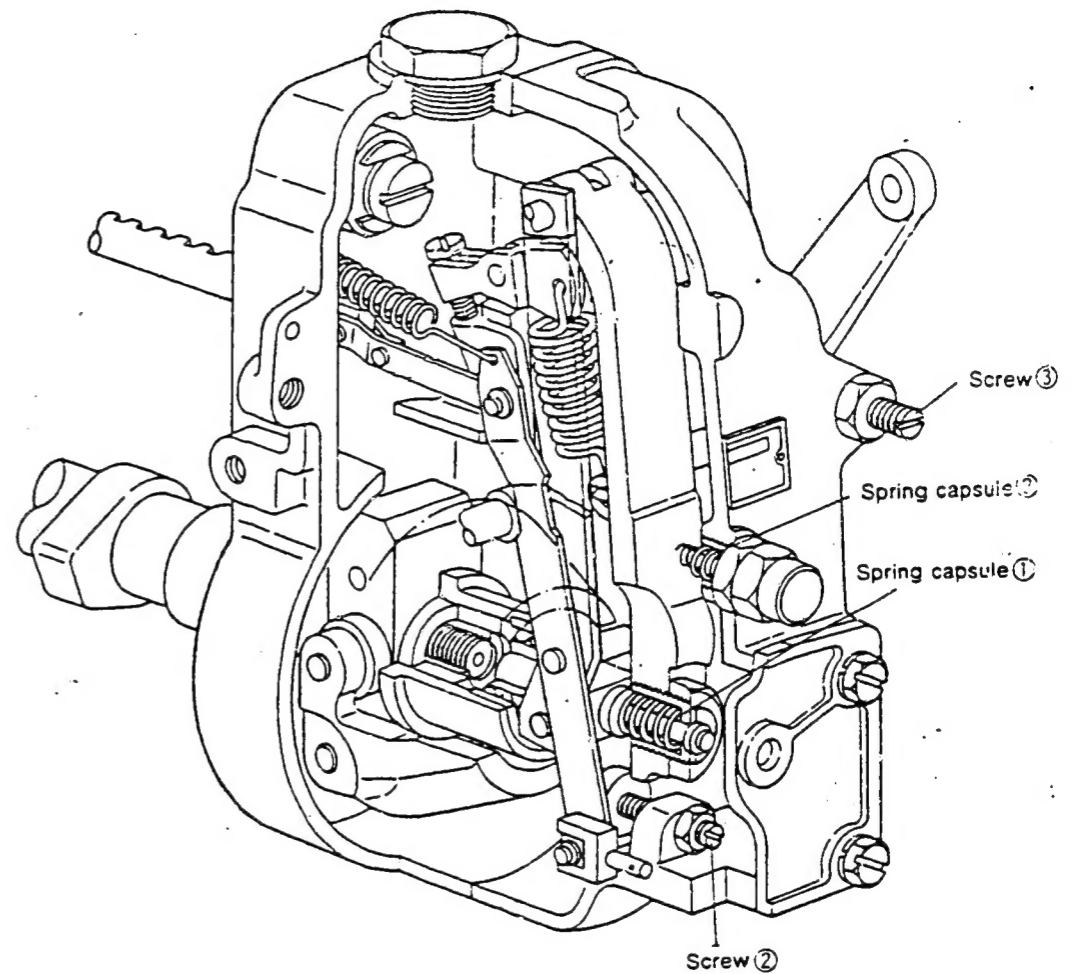

INJ. PUMP CALIBRATION DATA

ENGINE MODEL C240

BOSCH No. 9 400 610 050 1/4
 DKKC No. 101432 - 0220
 Date : 28, Oct. 1988
 Company : ISUZU
 No. 5156010871

B - 7

101432 - 0220 2/4

Injection pump : PES4A Governor : EP/RSV Timing device :
 101043-9170 105410-4340

1. Test Conditions :

Pump rotation : Counter clockwiseviewed from drive side

Nozzle & Nozzle Holder Ass'y : 105780-0000 (BOSCH Type No. DN12SD12T)
 Nozzle Holder : 105780-2080 (BOSCH Type No. EF8511/9A)
 Nozzle opening pressure : 175 kg/cm²
 Transfer pump pressure : 1.6 kg/cm²
 Injection pipe : Inner Dia. 2 mm x Outer Dia. 6 mm — Length 600 mm

Test Oil : ISO4113 or SAE Standard Test Oil (SAE J967d) Oil Temp. : 40±5°C
 Overflow valve opening pressure : — kg/cm²

2. Injection Timing :

Pre-stroke : No. 1 Plunger 2.25 ± 0.05 mm
 Note : Adjust with control rod position of mm
 Injection order : 1 ~ 3 ~ 4 ~ 2 (interval : 90° ± 30')
 Plungers are numbered from the Drive side.

Tappet clearance : Bolt adjustment type ; More than 0.3 mm for all cylinders.
 Shim adjustment type ; Manually rotate the camshaft 2 ~ 3 times and confirm that it rotates smoothly.

4. Injection Quantity :

Adjusting Point	Rod Position (mm)	Pump Speed (r.p.m.)	Injection Q'ty (cc/1000 strokes)	Max. var bet. cyl (%)	Fixed	Remarks
A	12.7	1,000	39.2 - 42.4	± 4	Rack	Basic
H	Approx. 7.9	350	6.9 - 9.1	± 14	Rack	
A	12.7	1,000	39.2 - 42.4	—	Level	
B	13	700	39.6 - 41.6	± 2.5	Lever	

5. Timing Advance Specification :

Pump Speed (r.p.m.)							
Advance Angle (deg)							

3. GOVERNOR ADJUSTMENT

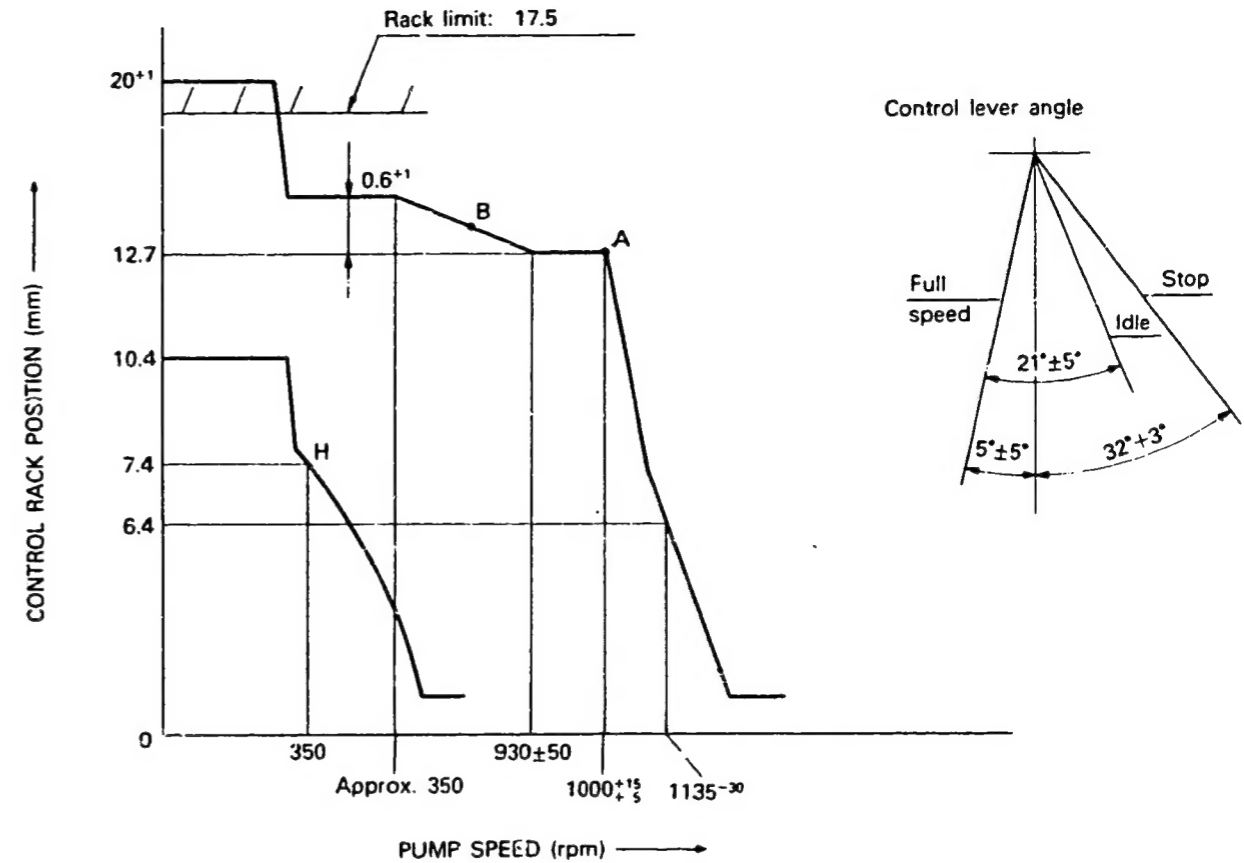

■ Note

1. Before adjustment, remove the idling sub spring and the torque control spring.
2. Move the control lever fully in the stop direction, and set the minimum-speed stopper bolt so that the control rack position is 0.5 ~ 1.0 mm.

■ Adjustment

Item	Pump Speed (rpm)	Rack Position (mm)	Remarks
Full-load Adjustment (Temporary)	1005 ~ 1015	12.7	• Adjust using screw 1
	950	12.7	• Adjust using screw 2
Torque Control Spring Adjustment	300	13.3 ~ 13.4	• Adjust using spring capsule 1
	Approx. 350	13.3 ~ 13.4	• Confirm
	980 ~ 780	12.7	• Confirm
	—	—	• Confirm the torque control stroke is mm.



DIESEL KIKI CO. LTD.
 Service Department

3-6-7 SHIBUYA, SHIBUYA-KU, TOKYO 150, JAPAN
 Tel (03)400-1551 · Fax (03)499-4115

Item	Pump Speed (rpm)	Rack Position (mm)	Remarks
Idling Adjustment	0 350 —	10.4 7.4 —	<ul style="list-style-type: none"> • Fix the control lever • Adjust using spring capsule ② • Confirm
Maximum-speed Adjustment	1005 - 1015 1105 - 1135	12.7 6.4	<ul style="list-style-type: none"> • Adjust using screw ① • Confirm speed droop • Confirm • Confirm
Full-load Adjustment (Install the cover on governor cover)	1000	12.7	<ul style="list-style-type: none"> • Adjust using screw ③
Control Lever Angle Measurement	<ul style="list-style-type: none"> • Measure the control lever angle at the "idling" and "full" positions. • When the control lever is depressed toward the "full" position, replace the shifter's shim with a thicker one. • When the control lever is depressed toward the "idling" position, replace the shifter's shim with a thinner one. 		
Rack Limiter Adjustment	0	17.5	<ul style="list-style-type: none"> • Adjust using screw

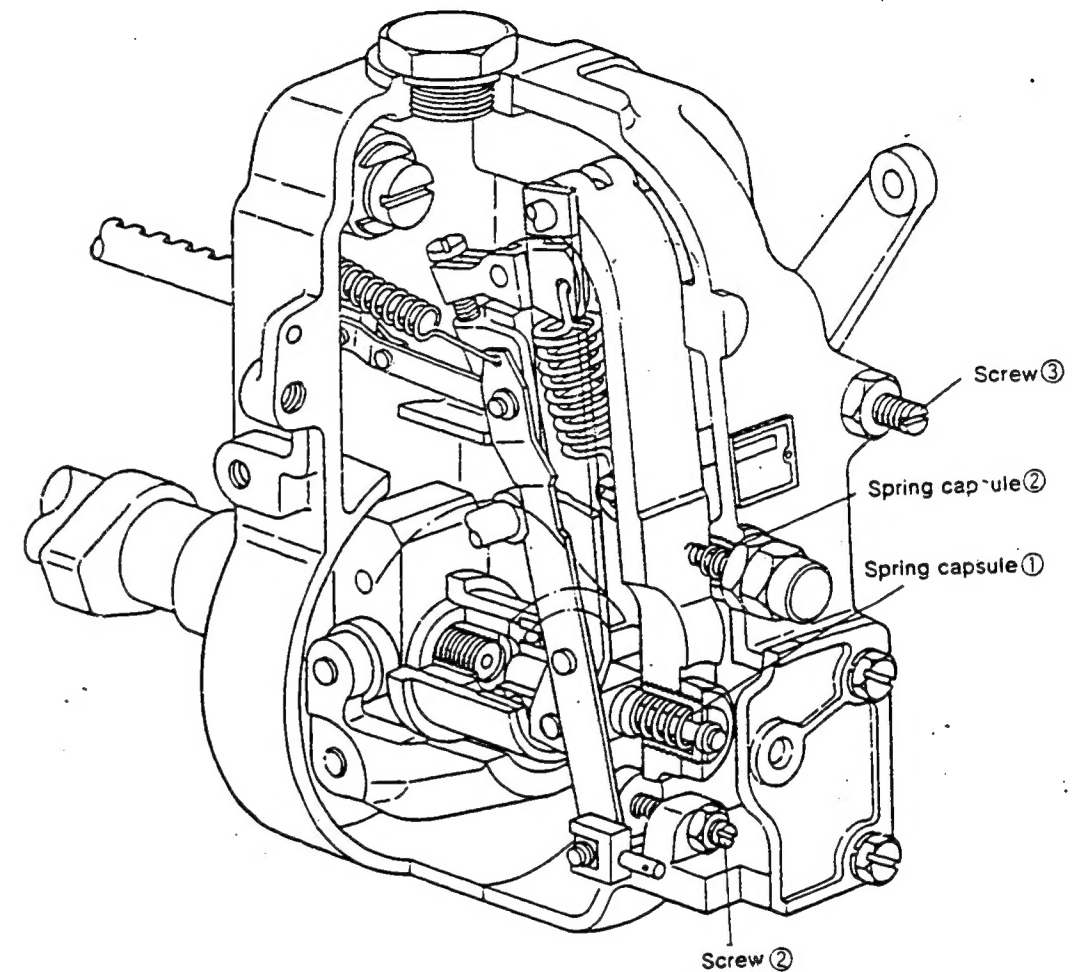

INJ. PUMP CALIBRATION DATA

ENGINE MODEL SD22

BOSCH No. 9 400 610 364 1/4
 DKKC No. 101433 - 9210
 Date : 28, Oct. 1988
 Company : NISSAN
 No. 16700L2500

Injection pump : PE34A Governor : EP/MZ Timing device : EP/SCD
 101043-8470 105520-3111 105622-0240

1. Test Conditions :

Pump rotation : clockwise viewed from drive side

Nozzle & Nozzle Holder Ass'y : 105780-0000 (BOSCH Type No. DN12SD12T)
 Nozzle Holder : 105780-2080 (BOSCH Type No. EF8511/9A)
 Nozzle opening pressure : 175 kg/cm²
 Transfer pump pressure : 1.6 kg/cm²
 Injection pipe : Inner Dia. 2 mm x Outer Dia. 6 mm — Length 800 mm

Test Oil : ISO4113 or SAE Standard Test Oil (SAE J967d) Oil Temp. : 40±5°C

Overflow valve opening pressure : kg/cm²

2. Injection Timing :

Pre-stroke : No. 1 Plunger 2.3 ± 0.05 mm

Note : Adjust with control rod position of mm

Injection order : 1 - 3 - 4 - 2

(interval : 90° ± 30')

Plungers are numbered from the Drive side.

Tappet clearance : Bolt adjustment type ; More than 0.3 mm for all cylinders.
 Shim adjustment type ; Manually rotate the camshaft 2 - 3 times and confirm that it rotates smoothly.

4. Injection Quantity :

Adjusting Point	Rod Position (mm)	Pump Speed (r.p.m.)	Injection Q'ty (cc/1000 strokes)	Max. var bet. cyl (%)	Fixed	Remarks
	14.9	800	35.6 ~ 37.6	± 2.5	Rack	Basic
	13.9	1,700	35.0 ~ 38.2	± 4	Rack	
	9	1,700	6.2 ~ 7.8	± 7.5	Rack	
	10.8	300	6.4 ~ 8.6	± 15	Rack	

5. Timing Advance Specification :

Pump Speed (r.p.m.)	Below 500	500	550	700	900	1100	1300	1500
Advance Angle (deg)	Start 0	Below 0.5	Below 0.7	1 ± 0.5	2 ± 0.5	3 ± 0.5	4 ± 0.5	5 ± 0.5

3. GOVERNOR ADJUSTMENT

B - 9

101433 - 9210 2/4

(1) Pneumatic Governor

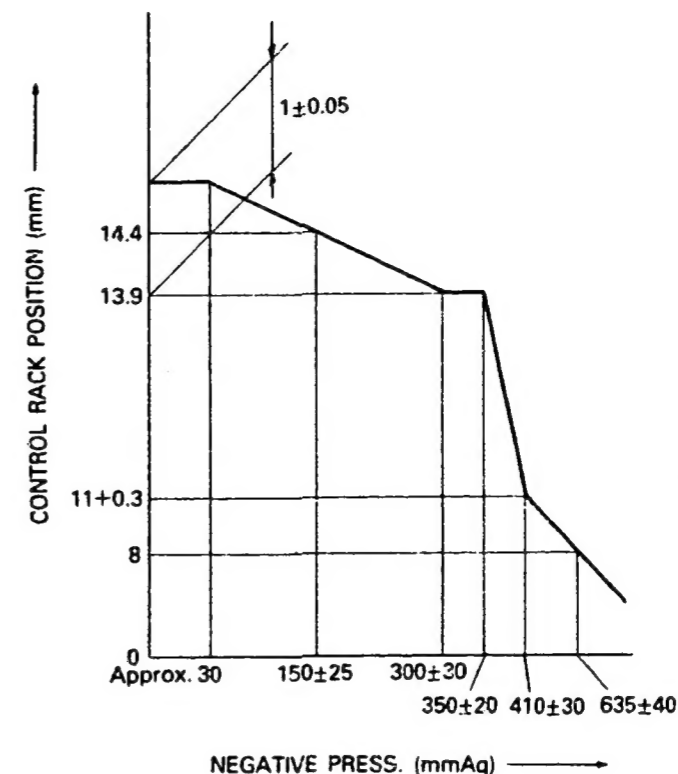

■ Air Tightness Test

- Increase the pressure of the pneumatic governor's negative pressure chamber to 500 mmAq at a pump speed of 500 rpm and a control rack position of Approx. 15 mm.
- Then, confirm that it takes 10 seconds or more for the negative pressure to fall from 500 mmAq to 480 mmAq.

■ Adjustment

- Pneumatic Governor (Pump Speed: 500 rpm)

Item	Negative Press. (mmAq)	Rack Position (mm)	Remarks
Smoke Set Screw Adjustment	0	14.85 ~ 14.95	• Adjust using spring capsule 1.
Torque Control Adjustment	① Start of torque control spring movement	Approx. 30	14.85 ~ 14.95 • Adjust thickness of shim ①.
	② End of torque control spring movement	270 ~ 330	13.9 • Adjust thickness of shim 2.
	③ Confirm	125 ~ 175	14.4
	④ Confirm torque control stroke	—	—



DIESEL KIKI CO. LTD.
 Service Department

3-6-7 SHIBUYA, SHIBUYA-KU, TOKYO 150, JAPAN
 Tel (03) 400-1551 Fax (03) 499-4115

Item	Negative Press. (mmAq)	Rack Position (mm)	Remarks
High-speed Control Adjustment	330 ~ 370	13.9	• Adjust thickness of shim ③.
Idling Adjustment	380 ~ 440 595 ~ 675	11.0 ~ 11.3 8.0	• Adjust using spring capsule ②. • Confirm

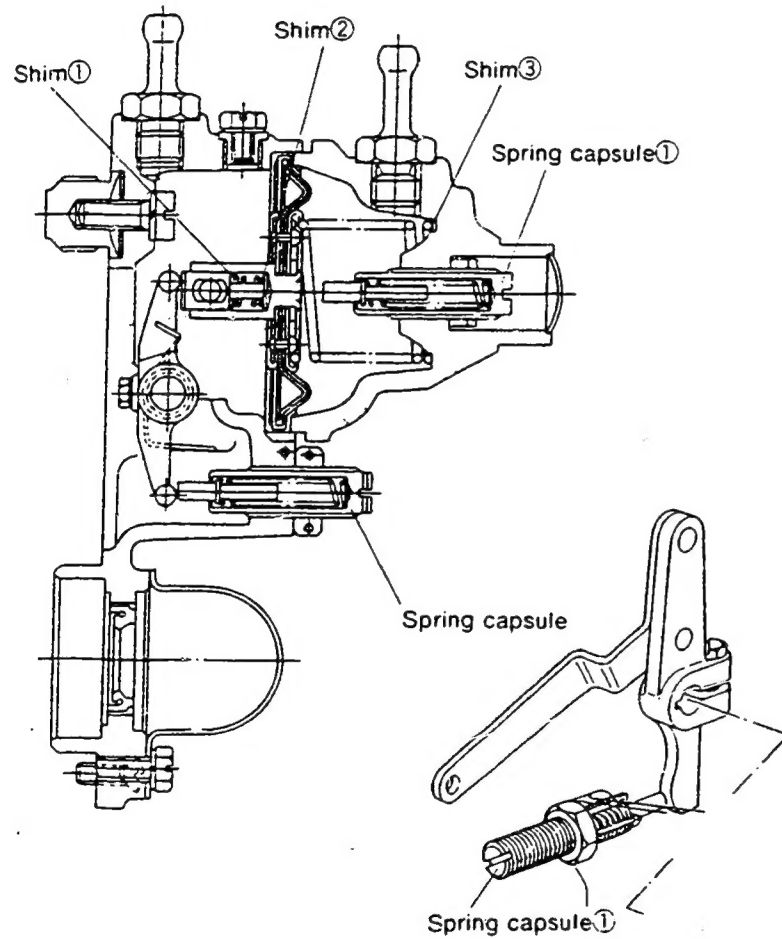

■ Final Adjustment

Smoke Setting			Fuel Injection Quantity Adjustment		
Pump Speed (rpm)	Negative Press. (mmAq)	Injection Q'ty (cc/1000st)	Pump Speed (rpm)	Negative Press. (mmAq)	Injection Q'ty (cc/1000st)
800	0	36.1 ~ 37.1			

■ Timing Setting

At No. 1 plunger's beginning of injection position.

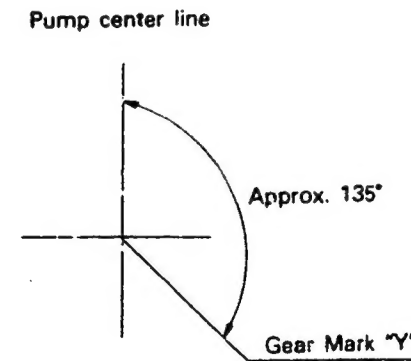

INJ. PUMP CALIBRATION DATA

ENGINE MODEL SD25

BOSCH No. 9 400 610 073 1/5
 DKKC No. 101441 - 9161
 Date : 28, Oct. 1988
 Company : NISSAN DIESEL
 No. 16700 54W61

B - 11

101441 - 9161 2/5

Injection pump : PES4A Governor : EP/RBD Timing device : EP/SCD
 101044-8100 105542-3900 105622-1230

1. Test Conditions :

Pump rotation : clockwise viewed from drive side

Nozzle & Nozzle Holder Ass'y : 105780-0000 Nozzle Holder : 105780-208U
 (BOSCH Type No. DN12SD12T) (BOSCH Type No. EF8511/9A)
 Nozzle opening pressure : 175 kg/cm² Transfer pump pressure : 1.6 kg/cm²
 Injection pipe : Inner Dia. 2 mm x Outer Dia. 6 mm - Length 600 mm

Test Oil : ISO4113 or SAE Standard Test Oil (SAE J967d) Oil Temp. : 40±5°C

Overflow valve opening pressure : - kg/cm²

2. Injection Timing :

Pre-stroke : No. 1 Plunger 2.15 ± 0.05 mm

Note : Adjust with control rod position of mm

Injection order : 1 - 3 - 4 - 2 (interval : 90° ± 30°)

Plungers are numbered from the Drive side.

Tappet clearance : Bolt adjustment type ; More than 0.3 mm for all cylinders.
 ; Shim adjustment type ; Manually rotate the camshaft 2 - 3 times and confirm that it rotates smoothly.

4. Injection Quantity :

Adjusting Point	Rod Position (mm)	Pump Speed (r.p.m.)	Injection Q'ty (cc/1000 strokes)	Max. var bet. cyl (%)	Fixed	Remarks
	12.3	1,000	3.1 ~ 5.1	± 2.5	Rack	Basic
	11.7	2,000	39.0 ~ 42.2	± 4	Rack	
	Approx. 8.2	300	6.9 ~ 9.1	± 15	Rack	
Full load set		1,000	42.1 ~ 43.1 (0 mmAq)			

5. Timing Advance Specification :

Pump Speed (r.p.m.)	500	800	1,200	1,800	2,000		
Advance Angle (deg)	Below 0.5	0.6 ± 0.5	2 ± 0.5	5 ± 0.5	6 ± 0.5		

3. GOVERNOR ADJUSTMENT

(1) Pneumatic Governor

(2) Mechanical Governor

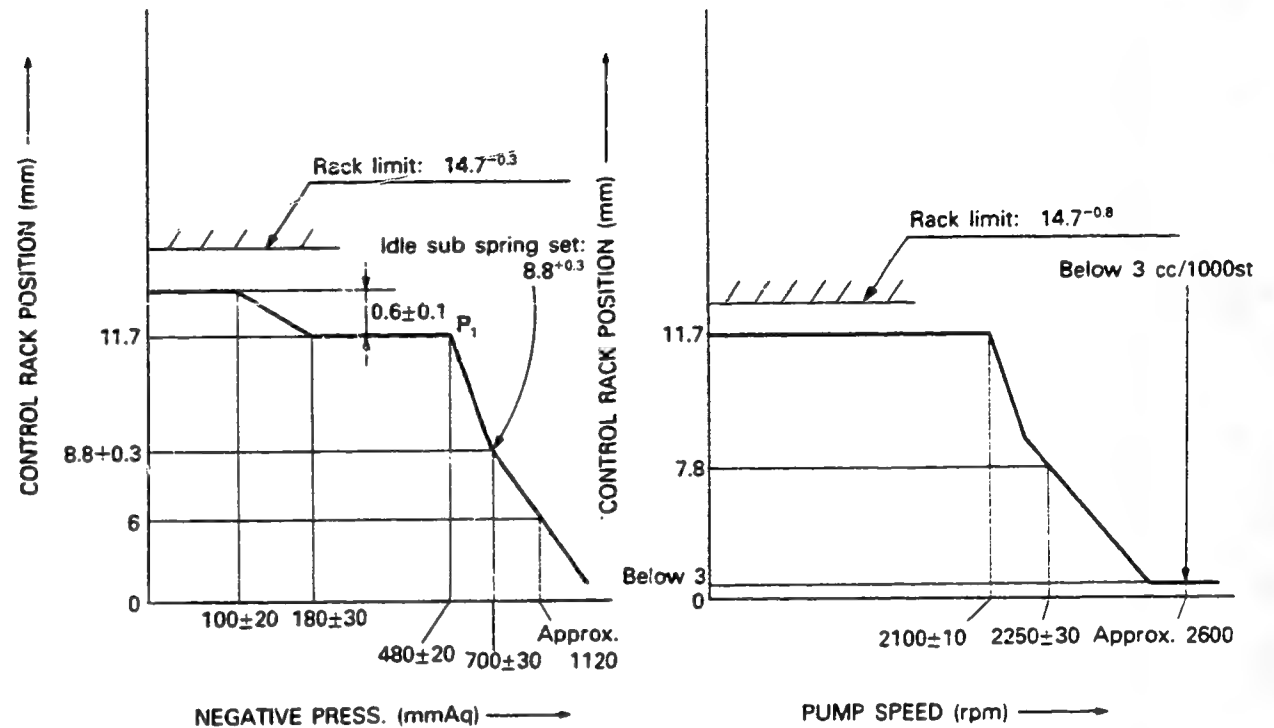

■ Air Tightness Test

1. Increase the pressure of the pneumatic governor's negative pressure chamber to 500 mmAq at a pump speed of 500 rpm and a control rack position of Approx. 12.3 mm.
2. Then, confirm that it takes 10 seconds or more for the negative pressure to fall from 500 mmAq to 480 mmAq.

■ Adjustment

1. Pneumatic Governor (Pump Speed: 500 rpm)

Item	Negative Press. (mmAq)	Rack Position (mm)	Remarks
Smoke Set Screw Adjustment	0	12.3	• Adjust using spring capsule 1.
Torque Control Adjustment	80 ~ 120	12.3	• Adjust thickness of shim 1.
		11.7	• Adjust thickness of shim 2.
	-	-	• Inspection: 0.5 ~ 0.7 mm



DIESEL KIKI CO. LTD. 3-6-7 SHIBUYA, SHIBUYA-KU, TOKYO 150, JAPAN
 Service Department Tel (03) 400-1551 Fax (03) 499-4115

Item	Negative Press. (mmAq)	Rack Position (mm)	Remarks
High-speed Control Adjustment	460 ~ 500	11.7	• Adjust thickness of shim ③.
Idling Adjustment	670 ~ 730 Approx. 1120	8.8 ~ 9.1 6.0	• Adjust using spring capsule ②. • Confirm

2. Mechanical Governor (Negative pressure: 460 ~ 500 mmAq)

Item	Pump Speed (rpm)	Rack Position (mm)	Remarks
Maximum Speed Control Adjustment	2090 ~ 2110	11.7	• Adjust using screw ①.
	2220 ~ 2280 Approx. 2600	7.8 Below 3	• Confirm • Confirm (Check the fuel injection quantity: below 3 cc/1000st)

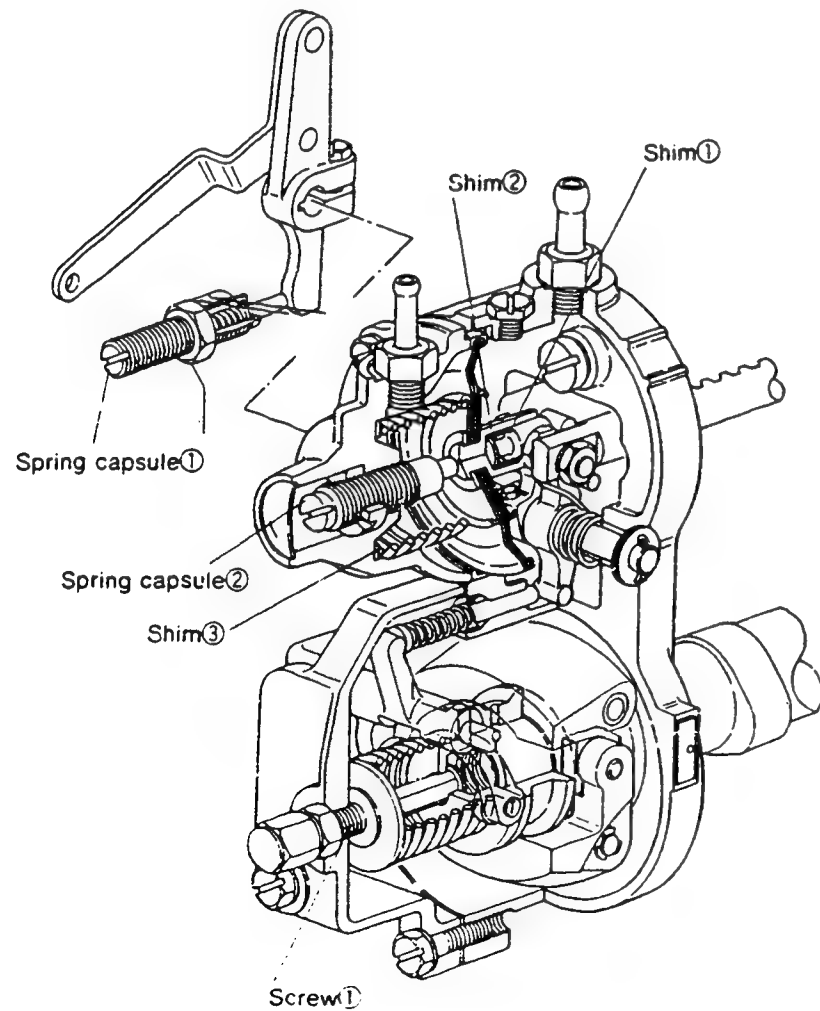

■ Final Adjustment

Smoke Setting			Fuel Injection Quantity Adjustment		
Pump Speed (rpm)	Negative Press. (mmAq)	Injection Q'ty (cc/1000st)	Pump Speed (rpm)	Negative Press. (mmAq)	Injection Q'ty (cc/1000st)
2000	11.7	39.0 ~ 42.2			

■ Timing Setting

At No. 1 plunger's beginning of injection position.

B.T.D.C.: 18°

Pump center line

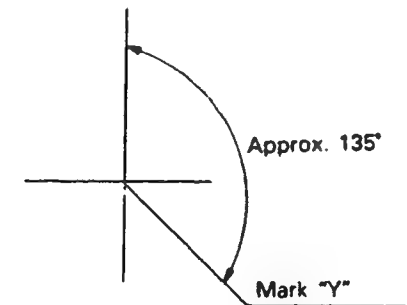

3. Aneroid Compensator Adjustment

1. Adjust using the setting screw so that the clearance between the housing and snap ring is 0.1 to 0.5 mm.
2. Attach the aneroid compensator assembly to the bracket.
3. Maintain the pump speed at 1000 rpm after adjustment of the RBD governor.
4. Confirm the control rod positions (11.7 mm and 12.3 mm) by the decreasing pressure of the pneumatic governor gradually from 0.
5. Loosen the cap and then screw in it until it just contacts the control lever pin.
6. Maintain the pump speed at 1000 rpm and reduce the pressure of the pneumatic governor's negative pressure chamber to 50 mmAq.
7. Adjust the cap so that the control rack moves 0.01 to 0.05 mm from the 12.3 mm position in the "fuel-decrease" direction and then secure with the nut.
8. Maintain the pump speed at 1000 rpm and reduce the pressure of the pneumatic governor's negative pressure chamber to 50 mmAq.
9. Ensure that the control rack moves to the 12.25 and 11.85 ~ 12.05 mm positions when the aneroid compensator pressure is reduced to 20 ~ 60 and 125 mmHg respectively.

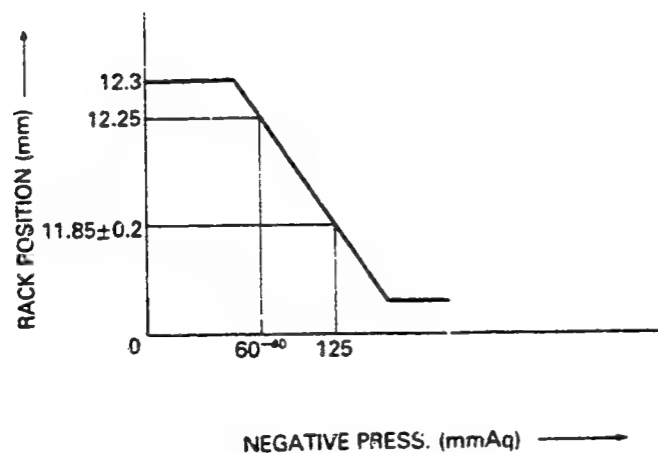

10. Readjust the setting screw if the performance of the aneroid compensator is not as specified.

INJ. PUMP CALIBRATION DATA

ENGINE MODEL SD23

BOSCH No. 9 400 610 074 1/5
 DKKC No. 101441 - 9171
 Date : 28, Oct. 1988 ⑩
 Company : NISSAN DIESEL
 No. 16700 09W61

B - 14

101441 - 9171 2/5

Injection pump : PES4A Governor : EP/R8D Timing device : EP/SCD
 101044-8100 105542-3910 105622-1060

1. Test Conditions :

Pump rotation : clockwise viewed from drive side

Nozzle & Nozzle Holder Ass'y : 105780-0000 Nozzle Holder : 105780-2080
 (BOSCH Type No. DN12SD12T) (BOSCH Type No. EF8511/9A)
 Nozzle opening pressure : 175 kg/cm² Transfer pump pressure : 1.6 kg/cm²
 Injection pipe :
 Inner Dia. 2 mm x Outer Dia. 6 mm — Length 600 mm

Test Oil : ISO4113 or SAE Standard Test Oil (SAE J967d) Oil Temp. : 40 °C

Overflow valve opening pressure : — kg/cm²

2. Injection Timing :

Pre-stroke : No. 1 Plunger 2.15 ± 0.05 mm

Note : Adjust with control rod position of mm

Injection order : 1 - 3 - 4 - 2 (interval : 90° ± 30')

Plungers are numbered from the Drive side.

Tappet clearance : Bolt adjustment type ; More than 0.3 mm for all cylinders.
 ; Shim adjustment type ; Manually rotate the camshaft 2 ~ 3 times and confirm that it rotates smoothly.

4. Injection Quantity :

Adjusting Point	Rod Position (mm)	Pump Speed (r.p.m.)	Injection Q'ty (cc/1000 strokes)	Max. var bet. cyl (%)	Fixed	Remarks
	12.0	1,000	37.8 ~ 39.8	± 2.5	Rack	Basic
	11.2	2,000	35.9 ~ 39.1	± 4	Rack	
	Approx. 8.2	300	6.9 ~ 9.1	± 15	Rack	
Full load set		1,000	38.3 ~ 39.3			

5. Timing Advance Specification :

Pump Speed (r.p.m.)	500	1,200	2,150			
Advance Angle (deg)	Below 0.5	2 ± 0.5	7 ± 0.5			

3. GOVERNOR ADJUSTMENT

(1) Pneumatic Governor

(2) Mechanical Governor

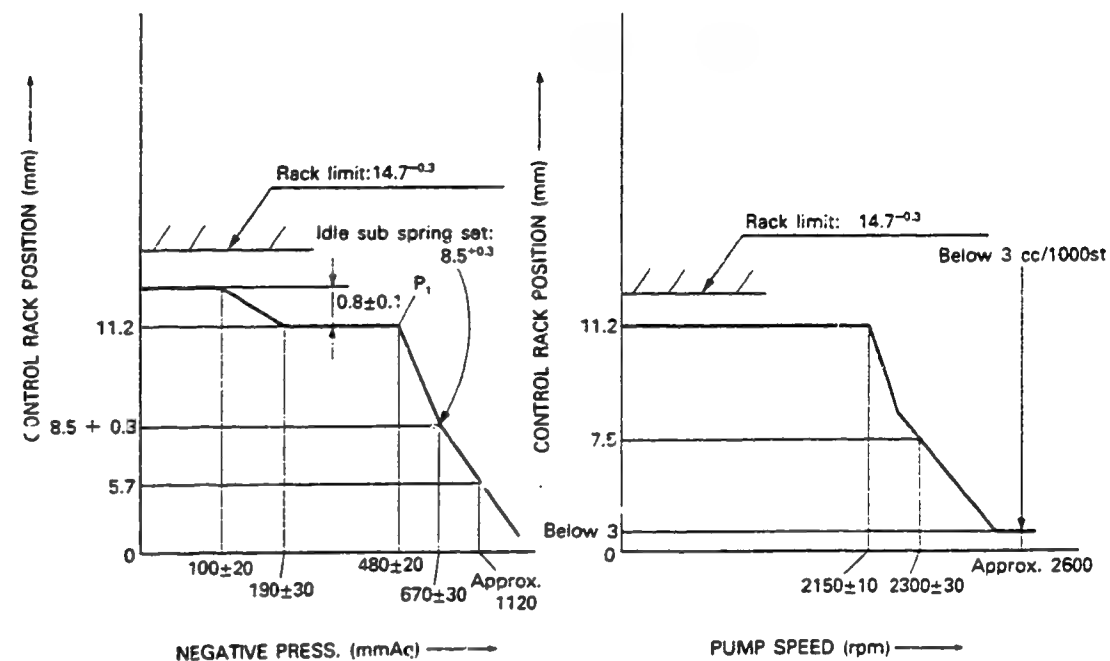

■ Air Tightness Test

1. Increase the pressure of the pneumatic governor's negative pressure chamber to 500 mmAq at a pump speed of 500 rpm and a control rack position of Approx. 12.0 mm.
2. Then, confirm that it takes 10 seconds or more for the negative pressure to fall from 500 mmAq to 480 mmAq.

■ Adjustment

Pneumatic Governor (Pump Speed: 500 rpm)

Item	Negative Press. (mmAq)	Rack Position (mm)	Remarks
Smoke Set Screw Adjustment	0	12.0	• Adjust using spring capsule ①.
Torque Control Adjustment			
① Start of torque control spring movement	80 ~ 120	12.3	• Adjust thickness of shim ①.
② End of torque control spring movement	80 ~ 220	12.3	• Adjust thickness of shim ②.
③ Confirm	—	—	
④ Confirm torque control stroke	—	—	• Inspection: 0.7 ~ 0.9 mm



DIESEL KIKI CO. LTD.
 Service Department

3-6-7 SHIBUYA, SHIBUYA-KU, TOKYO 150, JAPAN
 Tel (03) 400-1551 Fax (03) 499-4115

Item	Negative Press. (mmAq)	Rack Position (mm)	Remarks
High-speed Control Adjustment	460 ~ 500	11.2	• Adjust thickness of shim ③.
Idling Adjustment	640 ~ 700 Approx. 1120	8.5 ~ 8.8 5.7	• Adjust using spring capsule ②. • Confirm

2. Mechanical Governor (Negative pressure: 460 ~ 500 mmAq)

Item	Pump Speed (rpm)	Rack Position (mm)	Remarks
Maximum Speed Control Adjustment	2140 ~ 2160	11.2	• Adjust using screw ①.
	2270 ~ 2330 Approx. 2600	7.5 Below 3	• Confirm • Confirm (Check the fuel injection quantity: below 3 cc/1000st)

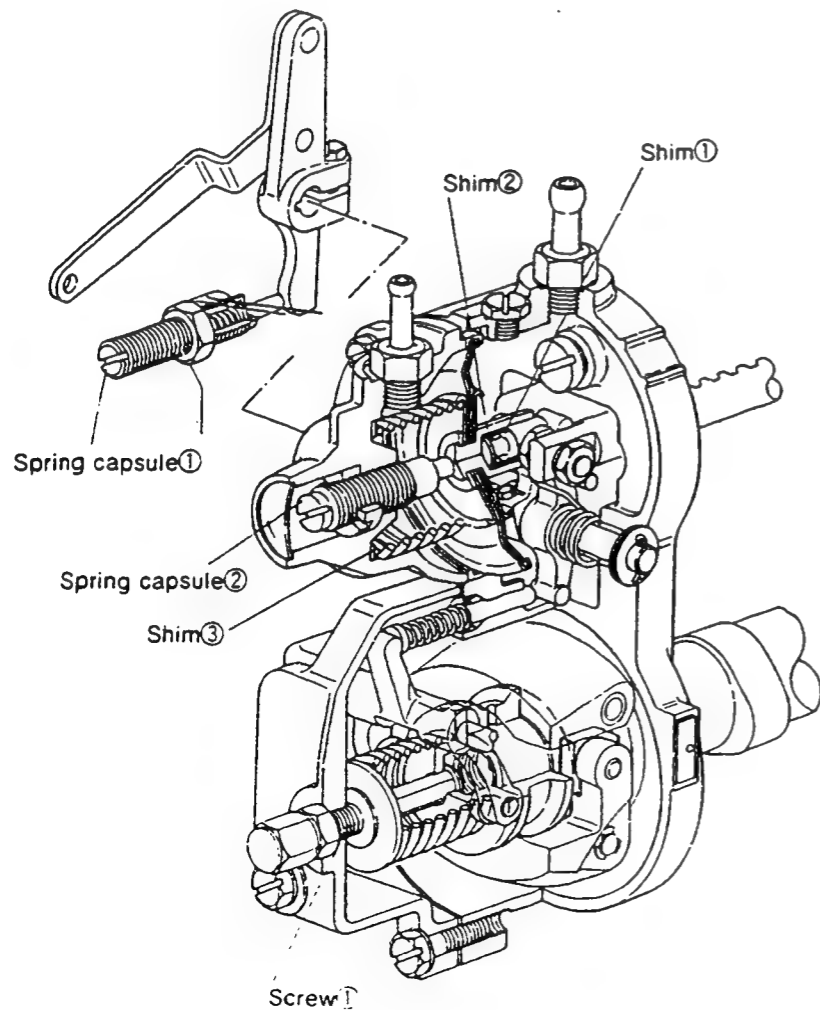

■ Final Adjustment

Smoke Setting			Fuel Injection Quantity Adjustment		
Pump Speed (rpm)	Negative Press. (mmAq)	Injection Q'ty (cc/1000st)	Pump Speed (rpm)	Negative Press. (mmAq)	Injection Q'ty (cc/1000st)
2000	480	35.9 ~ 39.1			

■ Timing Setting

At No. 1 plunger's beginning of injection position.

B.T.D.C.: 18°

Pump center line

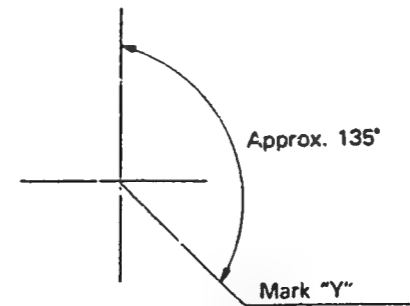

(3) Aneroid Compensator Adjustment

1. Adjust using the setting screw so that the clearance between the housing and snap ring is 0.1 to 0.5 mm.
2. Attach the aneroid compensator assembly to the bracket.
3. Maintain the pump speed at 1000 rpm after adjustment of the RBD governor.
4. Confirm the control rod positions (11.2 mm and 12.0 mm) by the decreasing pressure of the pneumatic governor gradually from 0.
5. Loosen the cap and then screw in it until it just contacts the control lever pin.
6. Maintain the pump speed at 1000 rpm and reduce the pressure of the pneumatic governor's negative pressure chamber to 50 mmAq.
7. Adjust the cap so that the control rack moves 0.01 to 0.05 mm from the 12.0 mm position in the "fuel-decrease" direction and then secure with the nut.
8. Maintain the pump speed at 1000 rpm and reduce the pressure of the pneumatic governor's negative pressure chamber to 50 mmAq.
9. Ensure that the control rack moves to the 11.95 and 11.35 ~ 11.75 mm positions when the aneroid compensator pressure is reduced to 20 ~ 60 and 125 mmHg respectively.

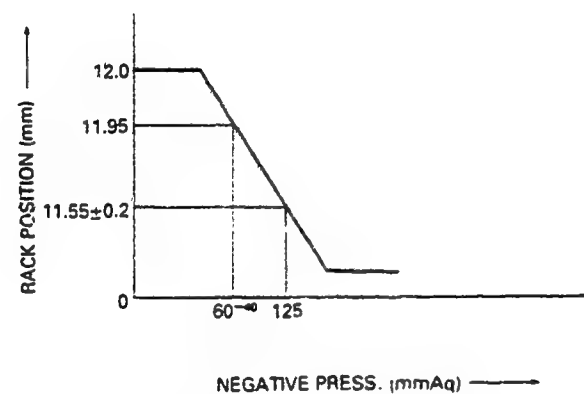

10. Readjust the setting screw if the performance of the aneroid compensator is not as specified.

INJ. PUMP CALIBRATION DATA

ENGINE MODEL SD23

BOSCH No. 9 400 610 0/5 1/4
 DKKC No. 101441 - 9420
 Date : 28. Oct. 1988
 Company : NISSAN DIESEL
 No. 16700 25G00

C - 1

101441 - 9420 2/4

Injection pump : PES4A Governor : EP/RBD Timing device : EP/SCD
 101044-8100 105542-4190 105622-1060

1. Test Conditions :

Pump rotation : clockwise viewed from drive side

Nozzle & Nozzle Holder Ass'y : 105780-0000 (BOSCH Type No. DN12SD12T)
 Nozzle Holder : 105780-2080 (BOSCH Type No. EF8511/9A)
 Nozzle opening pressure : 175 kg/cm²
 Transfer pump pressure : 1.6 kg/cm²

Injection pipe : Inner Dia. 2 mm x Outer Dia. 6 mm — Length 600 mm

Test Oil : ISO4113 or SAE Standard Test Oil (SAE J967d) Oil Temp. : 40±5°C

Overflow valve opening pressure : — kg/cm²

2. Injection Timing :

Pre-stroke : No. 1 Plunger 2.15 ± 0.05 mm

Note : Adjust with control rod position of mm

Injection order : 1 ~ 3 ~ 4 ~ 2 (interval : 90° ± 30')

Plungers are numbered from the Drive side.

Tappet clearance : Bolt adjustment type ; More than 0.3 mm for all cylinders.
 Shim adjustment type ; Manually rotate the camshaft 2 ~ 3 times and confirm that it rotates smoothly.

4. Injection Quantity :

Adjusting Point	Rod Position (mm)	Pump Speed (r.p.m.)	Injection Q'ty (cc/1000 strokes)	Max. var bet. cyl (%)	Fixed	Remarks
	12.0	1,000	37.8 ~ 39.8	± 2.5	Rack	Basic
	Approx. 7.5	300	6.9 ~ 9.1	± 15	Rack	

5. Timing Advance Specification :

Pump Speed (r.p.m.)	Below 550	500	1,200	2,150			
Advance Angle (deg)	Start	Below 0.5	1.5 ~ 2.5	Finish 6.5 ~ 7.5			

3. GOVERNOR ADJUSTMENT

(1) Pneumatic Governor

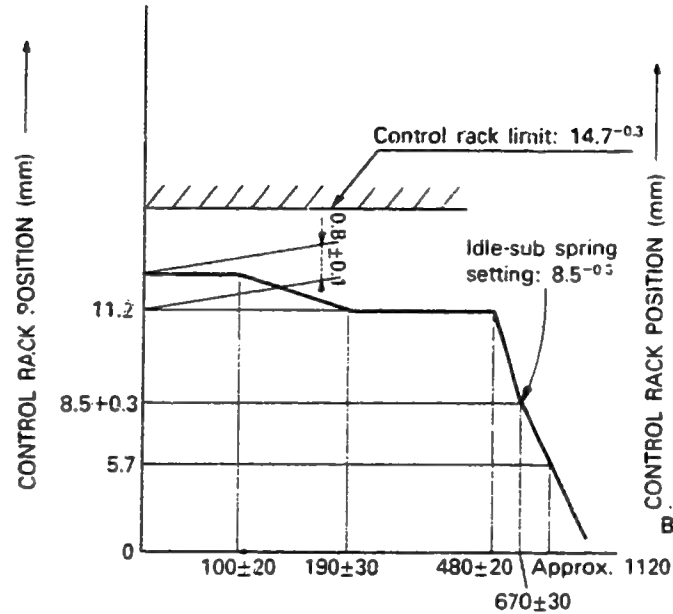

(2) Mechanical Governor

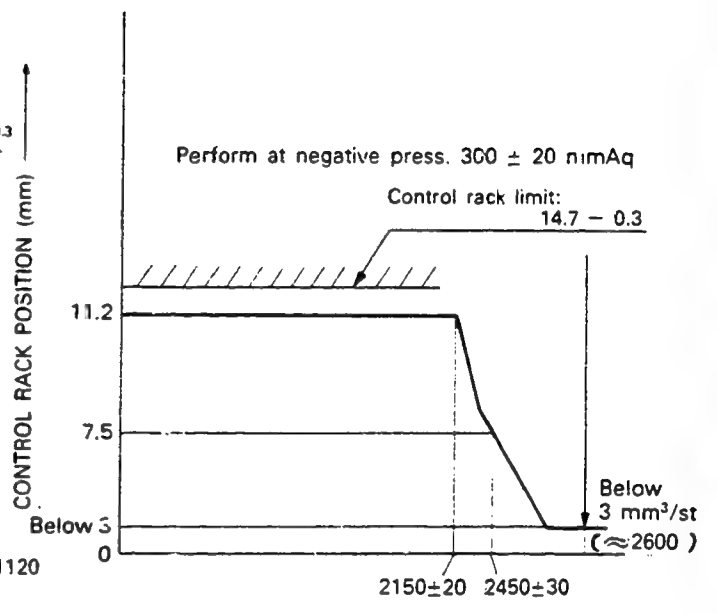

■ Air Tightness Test

- Increase the pressure of the pneumatic governor's negative pressure chamber to 500 mmAq at a pump speed of 500 rpm and a control rack position of 11.9 ~ 12.1.
- Then, confirm that it takes 10 seconds or more for the negative pressure to fall from 500 mmAq to 480 mmAq.

■ Adjustment

Pneumatic Governor (Pump Speed: 500 rpm)

Item	Negative Press. (mmAq)	Rack Position (mm)	Remarks	
Smoke Set Screw Adjustment	0	11.9 ~ 12.1	• Adjust using spring capsule 1.	
Torque Control Adjustment	1 Start of torque control spring movement	80 ~ 120	11.9 ~ 12.1	• Adjust thickness of shim 1.
	2 End of torque control spring movement	160 ~ 220	11.2	• Adjust thickness of shim 2.
3 Confirm	—	—	• Inspection: 0.7 ~ 0.9 mm	
4 Confirm torque control stroke	—	—		

Item	Negative Press. (mmAq)	Rack Position (mm)	Remarks
High-speed Control Adjustment	460 ~ 500	11.2	• Adjust thickness of shim ③.
Idling Adjustment	640 ~ 700 Approx. 1120	8.2 ~ 8.8 5.7	• Adjust using spring capsule ②. • Confirm

2. Mechanical Governor (Negative pressure: 300 ± 20 mmAq)

Item	Pump Speed (rpm)	Rack Position (mm)	Remarks
Maximum Speed Control Adjustment	2130 ~ 2170	11.2	• Adjust using screw ①.
	2420 ~ 2480 Approx. 2600	7.5 Below 3	• Confirm • Confirm (Check the fuel injection quantity: below 3 cc/1000st)

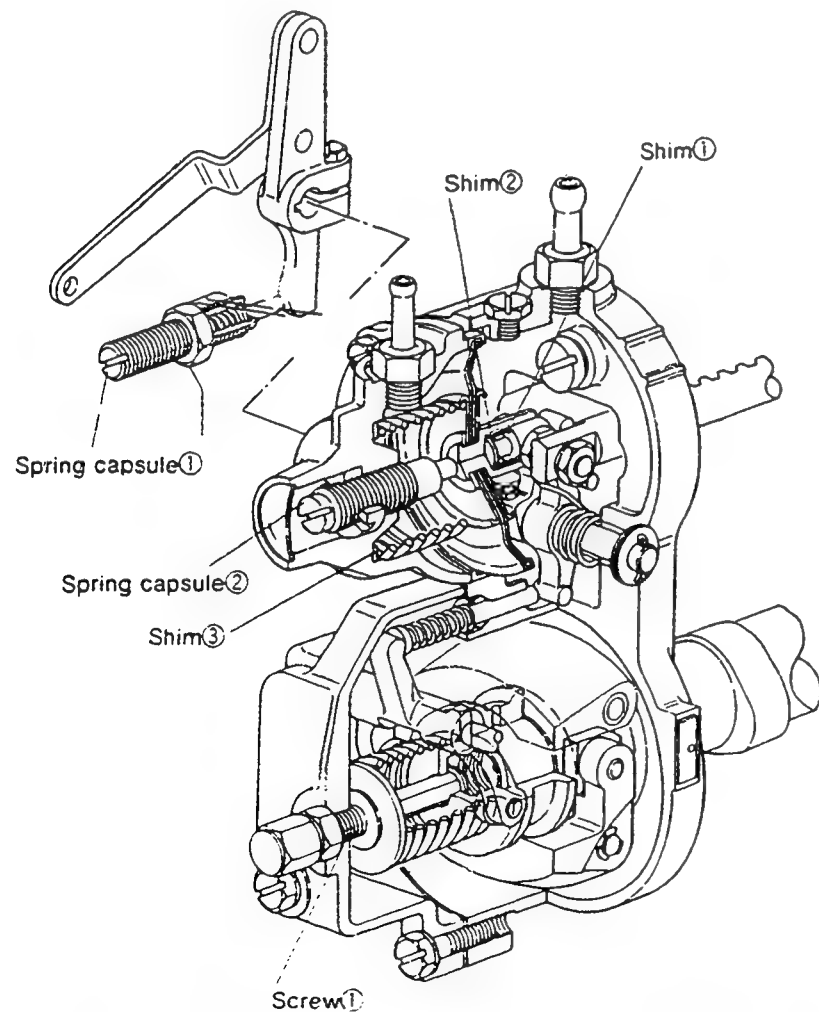

■ Final Adjustment

Smoke Setting			Fuel Injection Quantity Adjustment		
Pump Speed (rpm)	Negative Press. (mmAq)	Injection Q'ty (cc/1000st)	Pump Speed (rpm)	Negative Press. (mmAq)	Injection Q'ty (cc/1000st)
1000	280 ~ 320	37.8 ~ 39.8			

■ Timing Setting

At No. 1 plunger's beginning of injection position.

B.T.D.C.: 18°

Pump center line

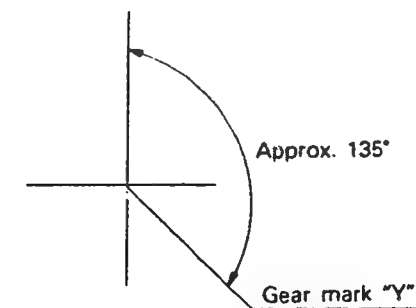

INJ. PUMP CALIBRATION DATA

ENGINE MODEL SD25

BOSCH No. 9 400 610 076 1/4
 DKKC No. 101441 - 9430
 Date : 28, Oct. 1988
 Company : NISSAN DIESEL
 No. 16700 39G00

C - 3

101441 - 9430 2/4

Injection pump : PES4A Governor : EP/RBD Timing device : EP/SCD
 101044-8100 105542-4200 105622-1230

1. Test Conditions :

Pump rotation : clockwise viewed from drive side

Nozzle & Nozzle Holder Ass'y : 105780-0000 Nozzle Holder : 105780-2080
 (BOSCH Type No. DN12SD12T) (BOSCH Type No. EF8511/9A)

Nozzle opening pressure : 175 kg/cm² Transfer pump pressure : 1.6 kg/cm²

Injection pipe :
 Inner Dia. 2 mm x Outer Dia. 6 mm — Length 600 mm

Test Oil : ISO4113 or SAE Standard Test Oil (SAE J967d) Oil Temp. : 40°C

Overflow valve opening pressure : — kg/cm²

2. Injection Timing :

Pre-stroke : No. 1 Plunger 2.15 ± 0.05 mm

Note : Adjust with control rod position of mm

Injection order : 1 - 3 - 4 - 2 (interval : 90° ± 30')

Plungers are numbered from the Drive side.

Tappet clearance : Bolt adjustment type : More than 0.3 mm for all cylinders.
 Shim adjustment type : Manually rotate the camshaft 2 ~ 3 times and confirm that it rotates smoothly.

4. Injection Quantity :

Adjusting Point	Rod Position (mm)	Pump Speed (r.p.m.)	Injection Q'ty (cc/1000 strokes)	Max. var bet. cyl (%)	Fixed	Remarks
	12.3	1,000	40.0 ~ 42.0	± 2.5	Rack	Basic
	11.7	2,000	39.0 ~ 42.2	± 4	Rack	
	Approx. 7.5	300	6.9 ~ 9.1	—	Lever	Basic

5. Timing Advance Specification :

Pump Speed (r.p.m.)	Below 550	500	800	1,200	1,800	2,000	
Advance Angle (deg)	Start	Below 0.5	0.1 ~ 1.1	1.5 ~ 2.5	4.5 ~ 5.5	Finish 5.5 ~ 6.5	

3. GOVERNOR ADJUSTMENT

(1) Pneumatic Governor

(2) Mechanical Governor

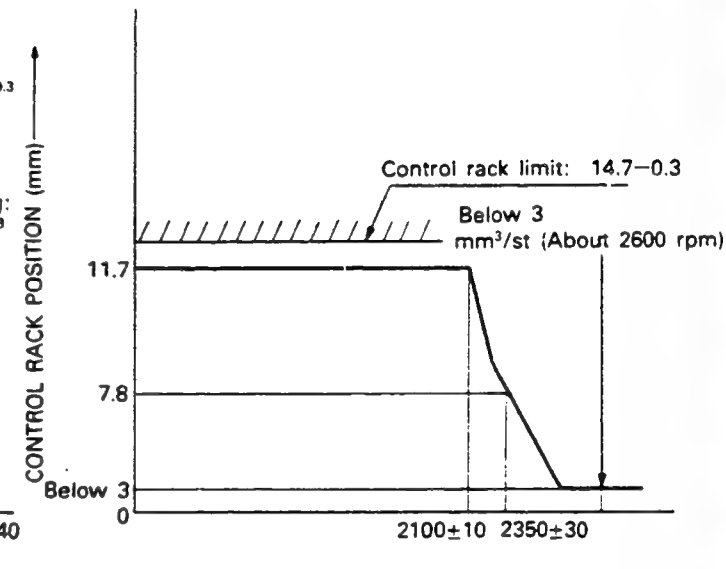
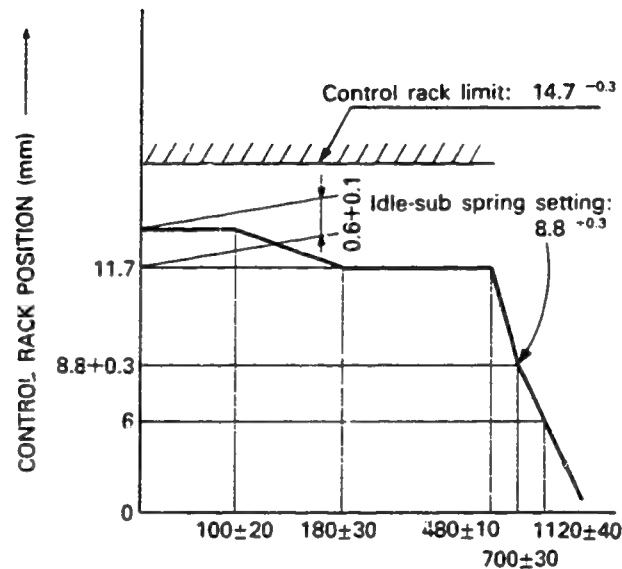

- Air Tightness Test
 1. Increase the pressure of the pneumatic governor's negative pressure chamber to 500 mmAq at a pump speed of 500 rpm and a control rack position of 12.3 mm.
 2. Then, confirm that it takes 10 seconds or more for the negative pressure to fall from 500 mmAq to 480 mmAq.
- Adjustment

Pneumatic Governor (Pump Speed: 500 rpm)

Item	Negative Press. (mmAq)	Rack Position (mm)	Remarks	
Smoke Set Screw Adjustment	0	12.3	• Adjust using spring capsule 1.	
Torque Control Adjustment	1. Start of torque control spring movement	80 ~ 120	12.3	• Adjust thickness of shim 1.
	2. End of torque control spring movement	150 ~ 210	11.2	• Adjust thickness of shim 2.
	3. Confirm	—	—	
	4. Confirm torque control stroke	—	—	• Inspection: 0.7 ~ 0.9 mm

Item	Negative Press. (mmAq)	Rack Position (mm)	Remarks
High-speed Control Adjustment	470 ~ 490	11.7	• Adjust thickness of shim 3.
Idling Adjustment	670 ~ 730 1080 ~ 1160	8.5 ~ 9.1 6.0	• Adjust using spring capsule 2. • Confirm

2. Mechanical Governor (Negative pressure: 470 ~ 490 mmAq)

Item	Pump Speed (rpm)	Rack Position (mm)	Remarks
Maximum Speed Control Adjustment	2090 ~ 2110	11.7	• Adjust using screw 1.
	2320 ~ 2380 Approx. 2600	7.8 Below 3	• Confirm • Confirm (Check the fuel injection quantity: below 3 cc/1000st)

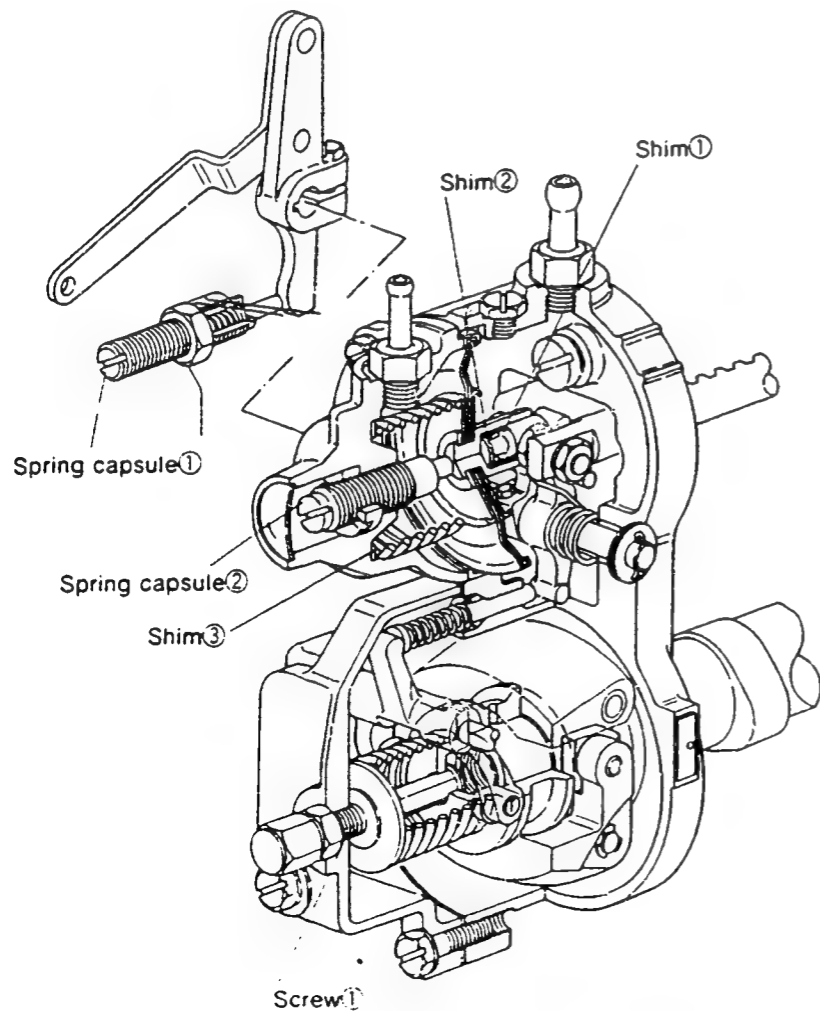

■ Final Adjustment

Smoke Setting			Fuel Injection Quantity Adjustment		
Pump Speed (rpm)	Negative Press. (mmAq)	Injection Q'ty (cc/1000st)	Pump Speed (rpm)	Negative Press. (mmAq)	Injection Q'ty (cc/1000st)
2000	11.7	39.0 ~ 42.2			

■ Timing Setting

At No. 1 plunger's beginning of injection position.
B.T.D.C.: 18°

Pump center line

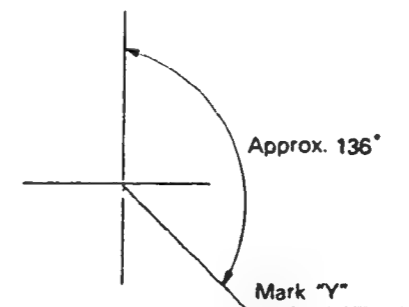

INJ. PUMP CALIBRATION DATA

ENGINE MODEL

BOSCH No. 9 400 610 077 1/5
 DKKC No. 101441 - 9490
 Date : 28, Oct. 1988
 Company : NISSAN DIESEL
 No. 16700 25G01

Injection pump : PES4A Governor : EP/RBD Timing device : EP/SCD
 101044-8100 105542-4400 105622-1060

1. Test Conditions :

Pump rotation : clockwise viewed from drive side

Nozzle & Nozzle Holder Ass'y : 105780-0000 (BOSCH Type No. DN12SD12T)
 Nozzle Holder : 105780-2080 (BOSCH Type No. EF8511/9A)
 Nozzle opening pressure : 175 kg/cm²
 Transfer pump pressure : 1.6 kg/cm²

Injection pipe : Inner Dia. 2 mm x Outer Dia. 6 mm - Length 600 mm

Test Oil : ISO4113 or SAE Standard Test Oil (SAE J967d) Oil Temp. : 40 ± 5°C

Overflow valve opening pressure : - kg/cm²

2. Injection Timing :

Pre-stroke : No. 1 Plunger 2.15 ± 0.05 mm

Note : Adjust with control rod position of mm

Injection order : 1 $\frac{90^\circ \pm 30'}{}$ 3, 1 $\frac{180^\circ \pm 30'}{}$ 4, 1 $\frac{270^\circ \pm 30'}{}$ 2 (interval : ° ± 30')

Plungers are numbered from the Drive side.

Tappet clearance : Bolt adjustment type : More than 0.3 mm for all cylinders.
 Shim adjustment type : Manually rotate the camshaft 2 ~ 3 times and confirm that it rotates smoothly.

4. Injection Quantity :

Adjusting Point	Rod Position (mm)	Pump Speed (r.p.m.)	Injection Qty (cc/1000 strokes)	Max. var bet. cyl (%)	Fixed	Remarks
	12.0	1,000	37.8 ~ 39.8	± 2.5	Rack	Basic
	11.2	2,000	35.9 ~ 39.1	± 4	Rack	
	Approx. 7.5	300	6.9 ~ 9.1		Lever	Basic

5. Timing Advance Specification :

Pump Speed (r.p.m.)	Below 550	500	1,200	2,150			
Advance Angle (deg)	Start	Below 0.5	1.5 ~ 2.5	Finish 6.5 ~ 7.5			

3. GOVERNOR ADJUSTMENT

C - 5

101441 - 9490 2/5

(1) Pneumatic Governor

(2) Mechanical Governor

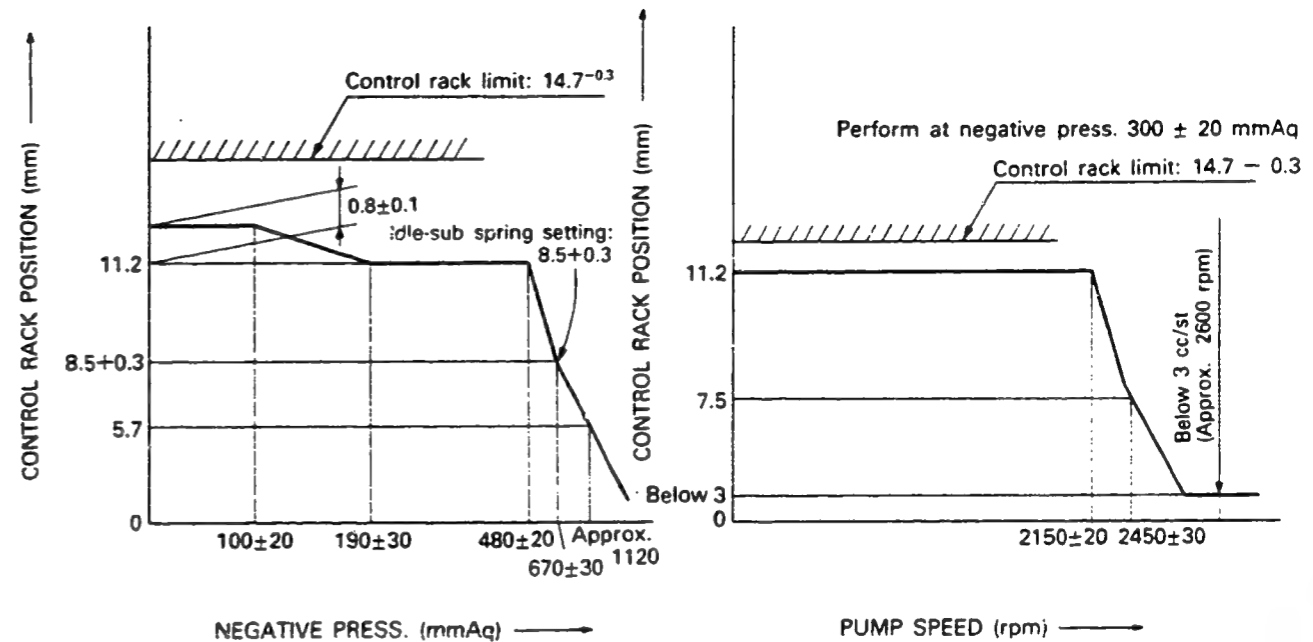

■ Air Tightness Test

1. Increase the pressure of the pneumatic governor's negative pressure chamber to 500 mmAq at a pump speed of 500 rpm and a control rack position of Approx. 12.0 mm.
2. Then, confirm that it takes 10 seconds or more for the negative pressure to fall from 500 mmAq to 480 mmAq.

■ Adjustment

(1) Pneumatic Governor (Pump Speed: 500 rpm)

Item	Negative Press. (mmAq)	Rack Position (mm)	Remarks
Smoke Set Screw Adjustment	0	11.9 ~ 12.1	• Adjust using spring capsule 1.
Torque Control Adjustment	80 ~ 120	11.9 ~ 12.1	• Adjust thickness of shim 1.
	160 ~ 220	11.2	• Adjust thickness of shim 2.
3 Confirm	-	-	• Inspection: 0.7 ~ 0.9 mm
4 Confirm torque control stroke	-	-	



DIESEL KIKI CO. LTD. 3-6-7 SHIBUYA, SHIBUYA-KU, TOKYO 150, JAPAN
 Service Department Tel (03) 400-1551 Fax (03) 499-4115

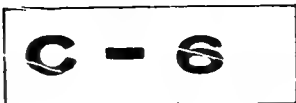

Item	Negative Press. (mmAq)	Rack Position (mm)	Remarks
High-speed Control Adjustment	460 - 500	11.2	• Adjust thickness of shim 3.
Idling Adjustment	640 - 700 Approx. 1120	8.5 - 8.8 5.7	• Adjust using spring capsule 2. • Confirm

(2) Mechanical Governor (Negative pressure: 280 - 320 mmAq)

Item	Pump Speed (rpm)	Rack Position (mm)	Remarks
Maximum Speed Control Adjustment	2150 - 2170	11.2	• Adjust using screw 1.
	2420 - 2480 Approx. 2600	7.5 Below 3	• Confirm • Confirm (Check the fuel injection quantity: below 3 cc/1000st)

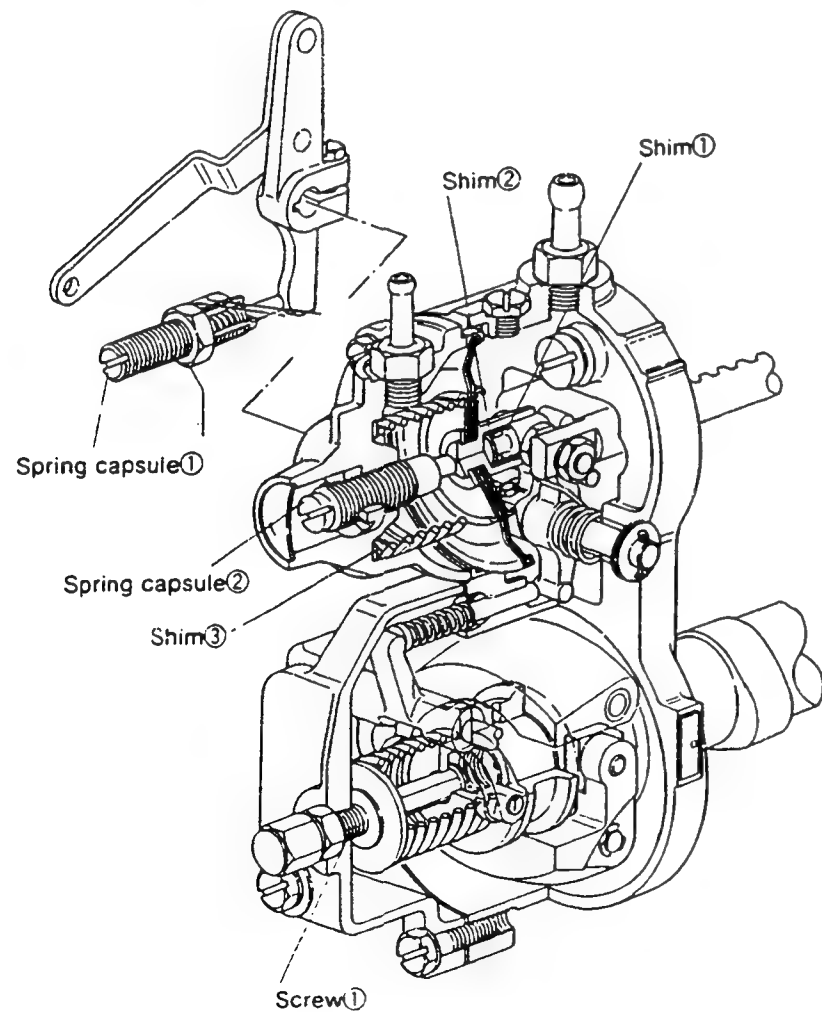

■ Final Adjustment

Smoke Setting			Fuel injection Quantity Adjustment		
Pump Speed (rpm)	Negative Press. (mmAq)	Injection Q'ty (cc/1000st)	Pump Speed (rpm)	Negative Press. (mmAq)	Injection Q'ty (cc/1000st)
2000	300	35.9 - 39.1			

■ Timing Setting

At No. 1 plunger's beginning of injection position.

B.T.D.C.: 18°

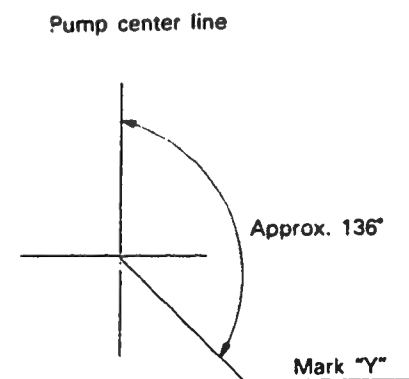

(3) Aneroid Compensator Adjustment

1. Adjust using the setting screw so that the clearance between the housing and snap ring is 0.1 to 0.5 mm.
2. Attach the aneroid compensator assembly to the bracket.
3. Maintain the pump speed at 1000 rpm after adjustment of the RBD governor.
4. Confirm the control rod positions (11.2 mm and 12.0 mm) by the decreasing pressure of the pneumatic governor gradually from 0.
5. Loosen the cap and then screw it until it just contacts the control lever pin.
6. Maintain the pump speed at 1000 rpm and reduce the pressure of the pneumatic governor's negative pressure chamber to 50 mmAq.
7. Adjust the cap so that the control rack moves 0.01 to 0.05 mm from the 12.0 mm position in the "fuel-decrease" direction and then secure with the nut.
8. Maintain the pump speed at 1000 rpm and reduce the pressure of the pneumatic governor's negative pressure chamber to 50 mmAq.
9. Ensure that the control rack moves to the 11.6 mm positions when the aneroid compensator pressure is reduced to 125 mmHg respectively.

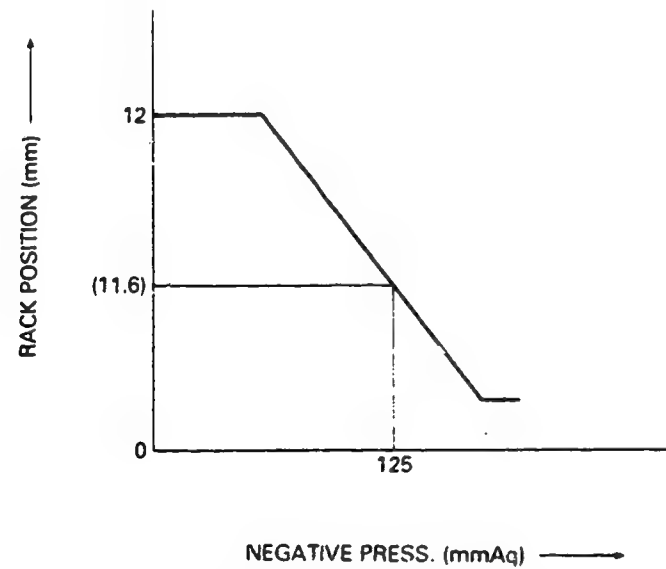

10. Readjust the setting screw if the performance of the aneroid compensator is not as specified.

INJ. PUMP CALIBRATION DATA

ENGINE MODEL SD25

BOSCH No. 9 400 610 078 1/5
 DKKC No. 101441 - 9500
 Date : 28, Oct. 1988
 Company : NISSAN DIESEL
 No. 16700 39G01

C - 8

101441 - 9500 2/5

Injection pump : PES4A Governor : EP/RBD Timing device : EP/SCD
 101C44-8100 105542-4410 105622-1230

1. Test Conditions :

Pump rotation : clockwiseviewed from drive side

Nozzle & Nozzle Holder Ass'y : 105780-0000 Nozzle Holder : 105780-2080
 (BOSCH Type No. DN12SD12T) (BOSCH Type No. EF8511/9A)
 Nozzle opening pressure : 175 kg/cm² Transfer pump pressure : 1.6 kg/cm²

Injection pipe :
 Inner Dia. 2 mm x Outer Dia. 6 mm - Length 600 mm

Test Oil : ISO4113 or SAE Standard Test Oil (SAE J967d) Oil Temp. : 40±5°C

Overflow valve opening pressure : - kg/cm²

2. Injection Timing :

Pre-stroke : No. 1 Plunger 2.15 ± 0.05 mm

Note : Adjust with control rod position of mm

Injection order : 1 $\frac{90^\circ \pm 30'}{3}$ 3, 1 $\frac{180^\circ \pm 30'}{4}$ 4, 1 $\frac{270^\circ \pm 30'}{2}$ (interval : ° ± 30')

Plungers are numbered from the Drive side.

Tappet clearance : Bolt adjustment type : More than 0.3 mm for all cylinders.
 : Shim adjustment type : Manually rotate the camshaft 2 - 3 times and confirm that it rotates smoothly.

4. Injection Quantity :

Adjusting Point	Rod Position (mm)	Pump Speed (r.p.m.)	Injection Q'ty (cc/1000 strokes)	Max. var bet. cyl (%)	Fixed	Remarks
	12.3	1,000	40.0 ~ 42.0	± 2.5	Rack	Basic
	11.7	2,000	39.0 ~ 42.2	± 4	Rack	
	Approx. 7.5	300	6.9 ~ 9.1	-	Lever	Basic

5. Timing Advance Specification :

Pump Speed (r.p.m.)	Below 550	500	800	1,200	1,800	2,000	
Advance Angle (deg)	Start	Below 0.5	0.1 ~ 1.1	1.5 ~ 2.5	4.5 ~ 5.5	Finish 5.5 ~ 6.5	

3. GOVERNOR ADJUSTMENT

(1) Pneumatic Governor

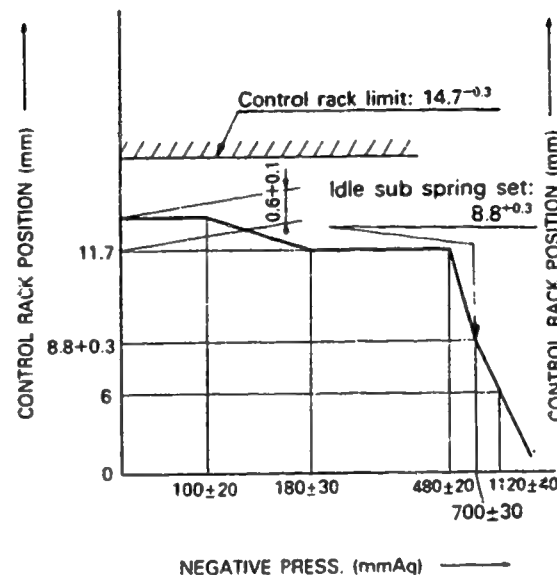

(2) Mechanical Governor

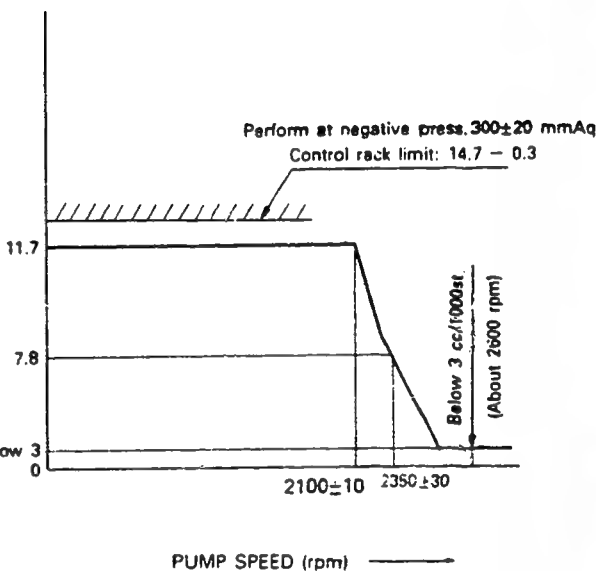

■ Air Tightness Test

- Increase the pressure of the pneumatic governor's negative pressure chamber to 500 mmAq at a pump speed of 500 rpm and a control rack position of Approx. 12.3 mm.
- Then, confirm that it takes 10 seconds or more for the negative pressure to fall from 500 mmAq to 480 mmAq.

■ Adjustment

(1) Pneumatic Governor (Pump Speed: 500 rpm)

Item	Negative Press. (mmAq)	Rack Position (mm)	Remarks
Smoke Set Screw Adjustment	0	12.2 ~ 12.4	• Adjust using spring capsule 1.
Torque Control Adjustment	80 ~ 120	12.2 ~ 12.4	• Adjust thickness of shim 1.
	150 ~ 210	11.7	• Adjust thickness of shim 2.
	-	-	
	-	-	• Inspection: 0.7 ~ 0.9 mm



DIESEL KIKI CO., LTD. 3-6-7 SHIBUYA, SHIBUYA-KU, TOKYO 150, JAPAN
 Service Department Tel (03) 400-1551 Fax (03) 499-4115

Item	Negative Press. (mmAq)	Rack Position (mm)	Remarks
High-speed Control Adjustment	460 ~ 500	11.7	• Adjust thickness of shim ③.
Idling Adjustment	670 ~ 730 1080 ~ 1160	8.5 ~ 9.1 6.0	• Adjust using spring capsule ②. • Confirm

2. Mechanical Governor (Negative pressure: 280 ~ 320 mmAq)

Item	Pump Speed (rpm)	Rack Position (mm)	Remarks
Maximum Speed Control Adjustment	2090 ~ 2110	11.7	• Adjust using screw ①.
	2320 ~ 2380	7.8	• Confirm
	Approx. 2600	Below 3	• Confirm (Check the fuel injection quantity: below 3 cc/1000st)

■ Final Adjustment

Smoke Setting			Fuel Injection Quantity Adjustment		
Pump Speed (rpm)	Negative Press. (mmAq)	Injection Q'ty (cc/1000st)	Pump Speed (rpm)	Negative Press. (mmAq)	Injection Q'ty (cc/1000st)
2000	280 ~ 320	39.2 ~ 42.2			

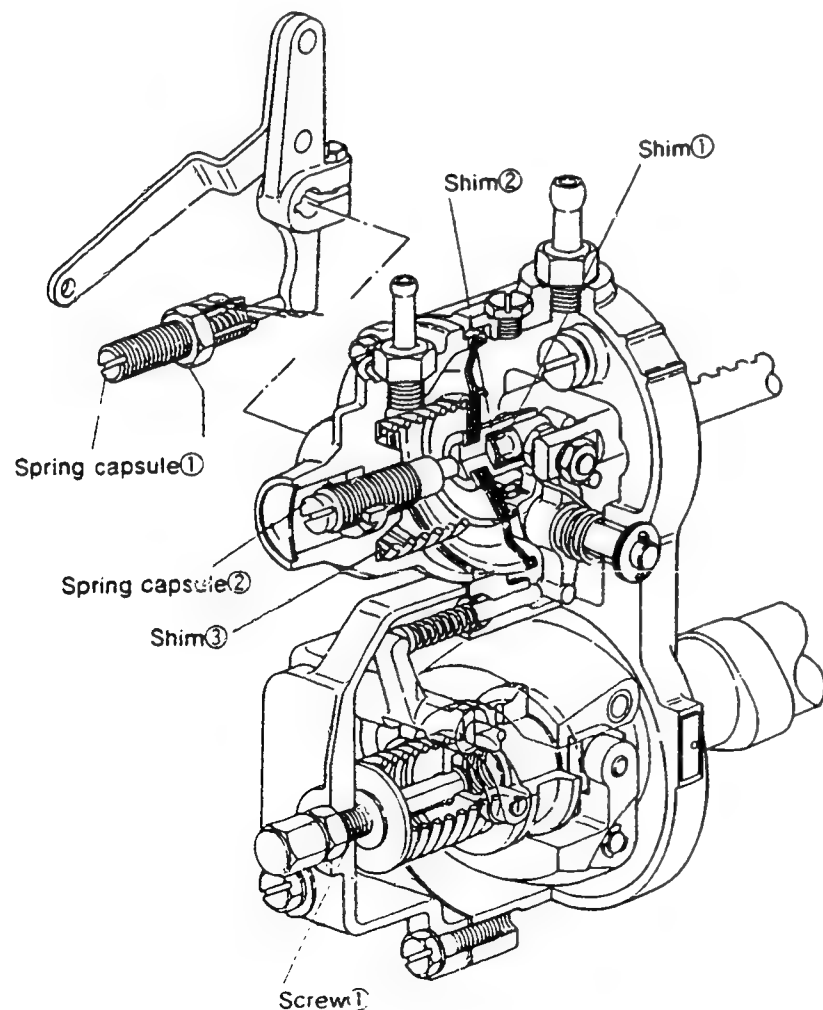

■ Timing Setting

At No. 1 plunger's beginning of injection position.

B.T.D.C.: 18°

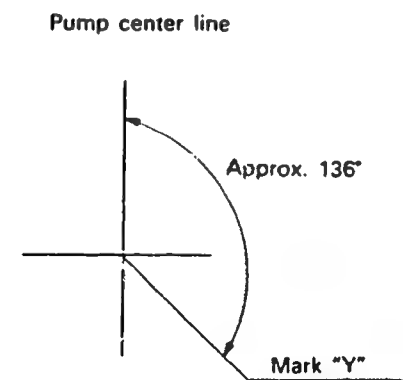

(3) Aneroid Compensator Adjustment

1. Adjust using the setting screw so that the clearance between the housing and snap ring is 0.1 to 0.5 mm.
2. Attach the aneroid compensator assembly to the bracket.
3. Maintain the pump speed at 1000 rpm after adjustment of the RBD governor.
4. Confirm the control rod positions (11.7 mm and 12.3 mm) by the decreasing pressure of the pneumatic governor gradually from 0.
5. Loosen the cap and then screw in until it just contacts the control lever pin.
6. Maintain the pump speed at 1000 rpm and reduce the pressure of the pneumatic governor's negative pressure chamber to 30 mmAq.
7. Adjust the cap so that the control rack moves 0.01 to 0.05 mm from the 12.3 mm position in the "fuel-decrease" direction and then secure with the nut.
8. Maintain the pump speed at 1000 rpm and reduce the pressure of the pneumatic governor's negative pressure chamber to 50 mmAq.
9. Ensure that the control rack moves to the 11.9 mm positions when the aneroid compensator pressure is reduced to 125 mmHg respectively.

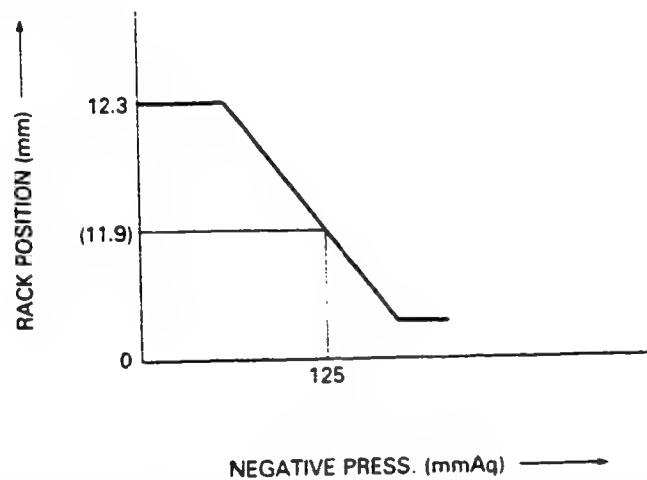

10. Readjust the setting screw if the performance of the aneroid compensator is not as specified.

INJ. PUMP CALIBRATION DATA

ENGINE MODEL 4BA1

BOSCH No. 9 400 610 062 1/4
 DKKC No. 101461 - 0201
 Date : 28. Oct. 1988
 Company : ISUZU
 No. 5156012310

C - 11

101461 - 0201 2/4

Injection pump : PES4A Governor : EP/RBD Timing device : EP/SCD
 101046-8160 105542-3580 105622-0701

1. Test Conditions :

Pump rotation : clockwiseviewed from drive side

Nozzle & Nozzle Holder Ass'y : 105780-0000 Nozzle Holder : 105780-2080
 (BOSCH Type No. DN12SD12T) (BOSCH Type No. EF8511/9A)
 Nozzle opening pressure : 175 kg/cm² Transfer pump pressure : 1.6 kg/cm²

Injection pipe :
 Inner Dia. 2 mm x Outer Dia. 6 mm - Length 600 mm

Test Oil : ISO4113 or SAE Standard Test Oil (SAE J967d) Oil Temp. : 40 °C

Overflow valve opening pressure : - kg/cm²

2. Injection Timing :

Pre-stroke : No. 1 Plunger 1.95 ± 0.05 mm

Note : Adjust with control rod position of mm

Injection order : 1 - 3 - 4 - 2 (interval : 90° ± 30')

Plungers are numbered from the Drive side.

Tappet clearance : Bolt adjustment type ; More than 0.3 mm for all cylinders.
 Shim adjustment type ; Manually rotate the camshaft 2 - 3 times and confirm that it rotates smoothly.

4. Injection Quantity :

Adjusting Point	Rod Position (mm)	Pump Speed (r.p.m.)	Injection Q'ty (cc/1000 strokes)	Max. var bet. cyl (%)	Fixed	Remarks
	11.8	500	40.3 - 44.3	± 4	Rack	Basic
	11.1	1,750	46.3 - 49.3	± 2.5	Rack	
	Above 8.9	300	7.1 - 9.9	± 14	Rack	
	Above 16.5	150	Above 75	-	Rack	Fuel excessive setting for start

5. Timing Advance Specification :

Pump Speed (r.p.m.)	500	700	1,000	1,400	1,750		
Advance Angle (deg)	Below 0.5	Below 1	1.5 ± 0.5	4 ± 0.5	6 + 1		

3. GOVERNOR ADJUSTMENT

(1) Pneumatic Governor

(2) Mechanical Governor

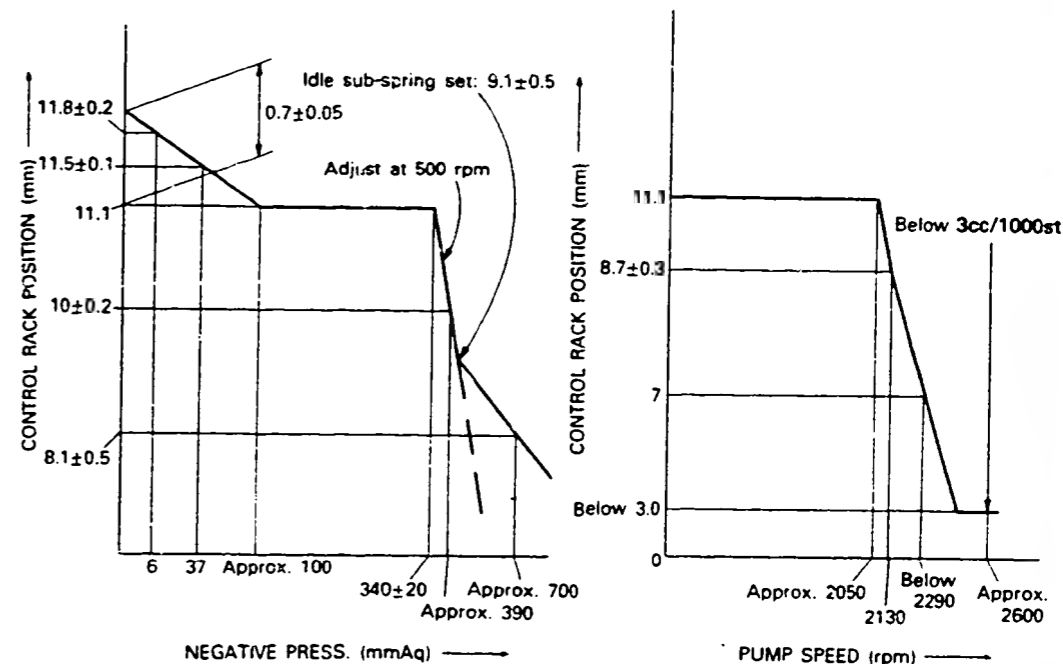

■ Air Tightness Test

1. increase the pressure of the pneumatic governor's negative pressure chamber to 500 mmAq at a pump speed of 500 rpm and a control rack position of 11.8 mm.
2. Then, confirm that it takes 10 seconds or more for the negative pressure to fall from 500 mmAq to 480 mmAq.

■ Adjustment

Pneumatic Governor (Pump Speed: 500 rpm)

Item	Negative Press. (mmAq)	Rack Position (mm)	Remarks
Smoke Set Screw Adjustment	0	Approx. 12	• Adjust using spring capsule 1.
Torque Control Adjustment			
1 Start of torque control spring movement	0	Approx. 12	• Adjust thickness of shim 1.
2 End of torque control spring movement	Approx. 100	11.1	• Adjust thickness of shim 2.
3 Confirm	37	11.4 - 11.5	
4 Confirm torque control stroke	-	-	• Inspection: 0.65 - 0.75 mm



DIESEL KIKI CO. LTD. 3-6-7 SHIBUYA, SHIBUYA-KU TOKYO 150 JAPAN
 Service Department Tel: (03) 400-1551 Fax: (03) 499-4115

Item	Negative Press. (mmAq)	Rack Position (mm)	Remarks
High-speed Control Adjustment	320 ~ 360	11.1	• Adjust thickness of shim ③.
Idling Adjustment	Approx. 390 Approx. 700	9.8 ~ 10.2 7.6 ~ 8.6	• Adjust using spring capsule ②. • Confirm

2. Mechanical Governor (Negative pressure: 320 ~ 360 mmAq)

Item	Pump Speed (rpm)	Rack Position (mm)	Remarks
Maximum Speed Control Adjustment	Approx. 2050	11.1	• Adjust using screw ①.
	2130 Below 2290	8.4 ~ 9.0 7.0	• Confirm • Confirm (Check the fuel injection quantity: below 3 cc/1000st)

■ Final Adjustment

Smoke Setting			Fuel Injection Quantity Adjustment		
Pump Speed (rpm)	Negative Press. (mmAq)	Injection Q'ty (cc/1000st)	Pump Speed (rpm)	Negative Press. (mmAq)	Injection Q'ty (cc/1000st)
1750	11.1	46.3 - 49.3			

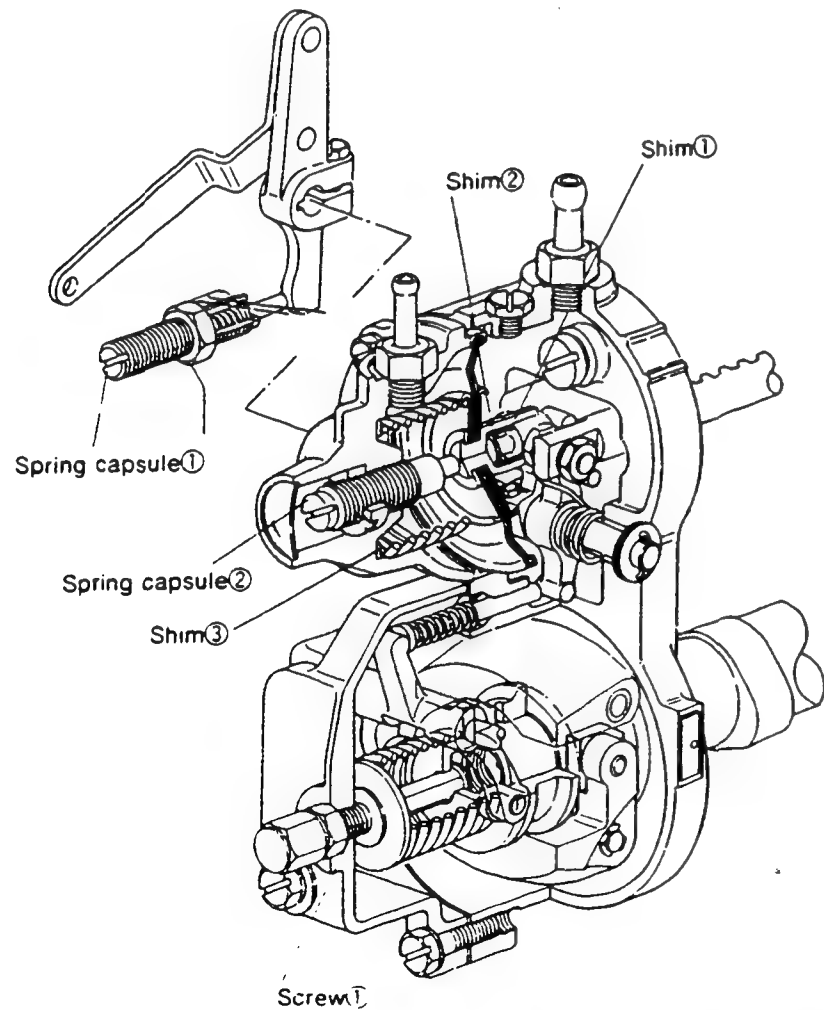

INJ. PUMP CALIBRATION DATA

ENGINE MODEL 6D14

BOSCH No. 9 400 610 081 1/4
 DKKC No. 101601 - 6781
 Date : 28, Oct. 1988
 Company : MITSUBISHI
 No. ME036846

Injection pump : PES6A Governor : EP/RFD Timing device : EP/SBZ
 101060-9480 105490-4200 105624-5090

1. Test Conditions :

Pump rotation : Counter clockwise viewed from drive side

Nozzle & Nozzle Holder Ass'y : 105780-0000 Nozzle Holder : 105780-2080
 (BOSCH Type No. DN12SD12T) (BOSCH Type No. EF8511/9A)
 Nozzle opening pressure : 175 kg/cm² Transfer pump pressure : 1.6 kg/cm²
 Injection pipe :
 Inner Dia. 2 mm x Outer Dia. 6 mm — Length 600 mm

Test Oil : ISO4113 or SAE Standard Test Oil (SAE J967d) Oil Temp. : 40 ± 5°C

Overflow valve opening pressure : 2.6 kg/cm²

2. Injection Timing :

Pre-stroke : No. 1 Plunger 3.3 ± 0.05 mm

Note : Adjust with control rod position of mm

Injection order : 1 - 5 - 3 - 6 - 2 - 4 (interval: 60° ± 30')

Plungers are numbered from the Drive side.

Tappet clearance : Bolt adjustment type ; More than 0.3 mm for all cylinders.

4. Injection Quantity :

Adjusting Point	Rod Position (mm)	Pump Speed (r.p.m.)	Injection Q'ty (cc/1000 strokes)	Max. var bet. cyl (%)	Fixed	Remarks
	11.5	850	59.7 - 63.3	—	Rack	Basic
H	Approx. 9.5	275	9 - 12	—	Rack	
A	R ₁ (11.5)	850	60.5 - 62.5	—	Lever	
B	R ₁ (11.5)	1,500	qA + 1.6 ≤ qB ≤ qA + 7	5.4	Lever	
C	R _{1+0.8}	450	—	—	Lever	

5. Timing Advance Specification :

Pump Speed (r.p.m)	850	900	1,200	1,500			
Advance Angle (deg)	Below 0.5	Below 0.8	2.6 ± 0.5	5.5 ± 0.5			



DIESEL KIKI CO. LTD.
 Service Department

3-6-7 SHIBUYA, SHIBUYA-KU TOKYO 150 JAPAN
 Tel (03) 400-1551 Fax (03) 499-4115

3. GOVERNOR ADJUSTMENT

C - 13

101601 - 6781 2/4

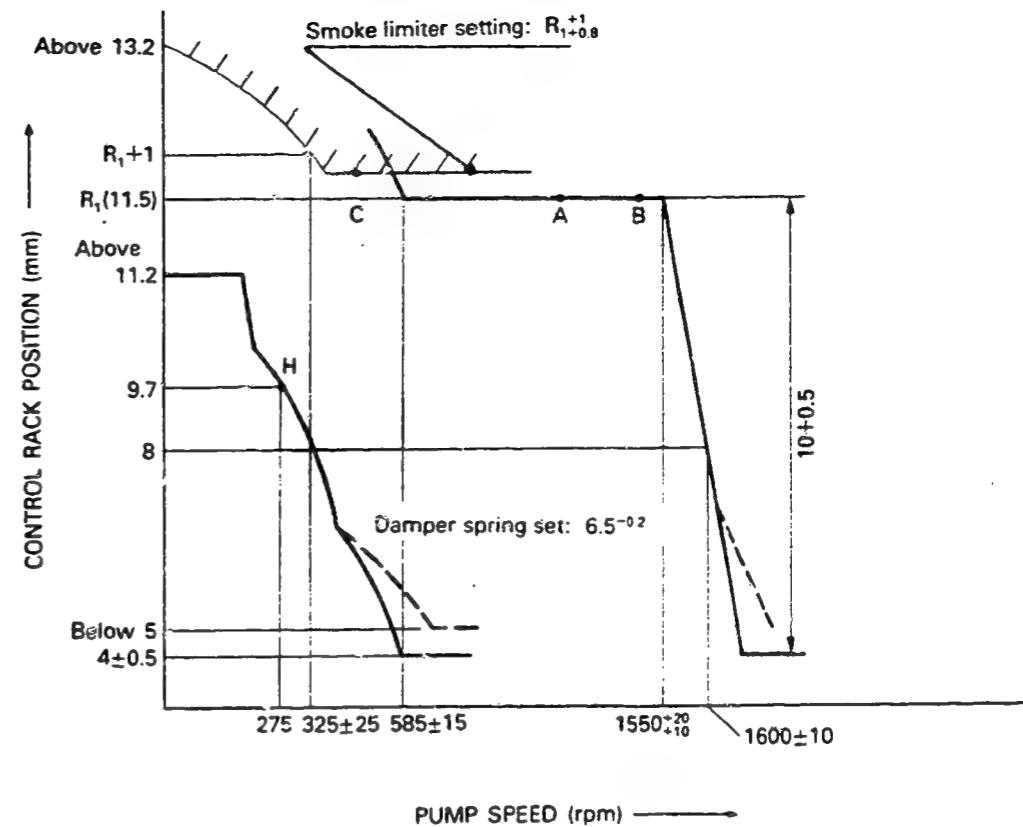

• LOAD CONTROL LEVER ANGLE

• SPEED CONTROL LEVER ANGLE

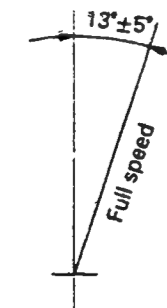
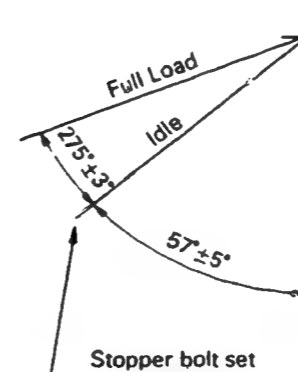

■ Note

Before adjustment, remove the damper spring, the cover and the idling spring capsule.

■ Adjustment

Item	Pump Speed (rpm)	Rack Position (mm)	Remarks
Flyweight Lift And Full-Load Position	700 ~ 800 Approx. 1600	11.5 Approx. 1.0	<ul style="list-style-type: none"> • Speed control lever: temporary setting. • Adjust using screw ①.
	Decrease pump speed to 1550 ± 10 rpm and adjust the high speed lift value (10 ± 0.5) using screw ②.		
Idling Adjustment	570 ~ 600 275	3.5 ~ 4.5 9.7	<ul style="list-style-type: none"> • Adjust using screw ③. • Adjust using spring capsule ④ • Confirm • Confirm • Confirm the control lever angle is ($52^\circ \sim 62^\circ$)
	570 ~ 600 275	3.5 ~ 4.5 9.7	
Damper Spring Setting	Maintain the pump speed at 275 rpm and set the control rod at the 9.7 mm position using the control lever. Then, gradually increase the pump speed until the rod position is $6.5^{+0.2}$ mm. Tighten the damper spring capsule and fix it in the position where it begins to move the rod from the $6.5^{+0.2}$ mm position.		
Maximum Speed Starting Point and Speed Droop Check	Fix the load control lever in the full-load position and fix the speed control lever in the full-speed position.		
	1550 ± 10 1600 ± 10 Approx. 1610	11.5 8.0 —	<ul style="list-style-type: none"> • Adjust using screw ④. • Confirm • Confirm that there is no fuel injection.
Smoke Limiter Setting	Fix the load control lever in the full-load position.		
	— Below 100	— Above 13.2	<ul style="list-style-type: none"> • Adjust using smoke limiter. • Confirm injection quantity at point E.

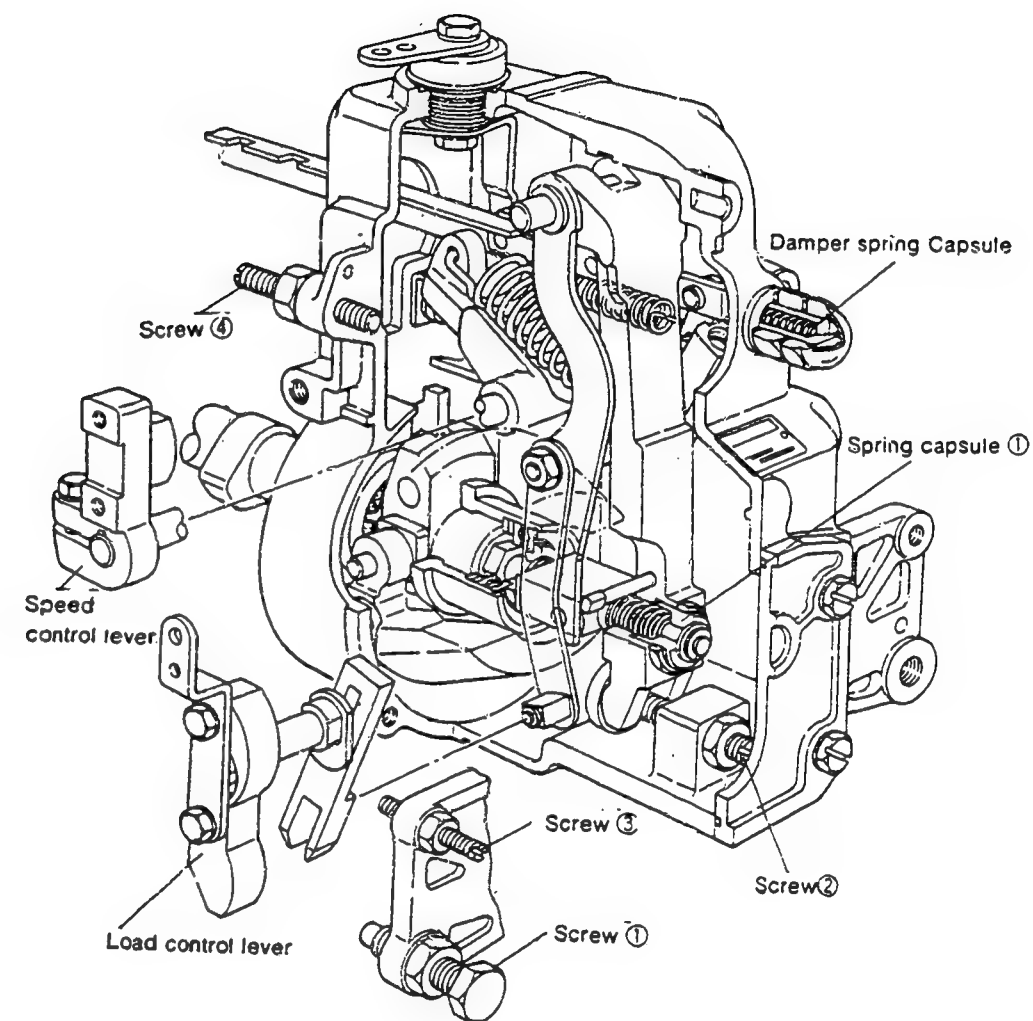

INJ. PUMP CALIBRATION DATA

ENGINE MODEL SD33T

BOSCH No. 9 400 610 065 1/6
 DKKC No. 101641 - 9143
 Date : 28, Oct. 1988
 Company : NISSAN DIESEL
 No. 16713-L9003

D - 1

101641 - 9143 2/6

Injection pump : PES6A Governor : EP/RLD Timing device : EP/SCD
 101064-9030 105931-2521 105E22-0680

1. Test Conditions :

Pump rotation : clockwiseviewed from drive side

Nozzle & Nozzle Holder Ass'y : 105780-0000 Nozzle Holder : 105780-2080
 (BOSCH Type No. DN12SD12T) (BOSCH Type No. EP8511/9A)
 Nozzle opening pressure : 175 kg/cm² Transfer pump pressure : 1.6 kg/cm²
 Injection pipe :
 Inner Dia. 2 mm x Outer Dia. 6 mm — Length 600 mm

Test Oil : ISO4113 or SAE Standard Test Oil (SAE J967d) Oil Temp. : 40[±]5°C

Overflow valve opening pressure : kg/cm²

2. Injection Timing :

Pre-stroke : No. 1 Plunger 2.3 ± 0.05 mm

Note : Adjust with control rod position of mm

Injection order : 1 - 4 - 2 - 6 - 3 - 5 (interval: 60° ± 30')

Plungers are numbered from the Drive side.

Tappet clearance : Bolt adjustment type ; More than 0.3 mm for all cylinders.

4. Injection Quantity :

Adjusting Point	Rod Position (mm)	Pump Speed (r.p.m.)	Injection Q'ty (cc/1000 strokes)	Max. var bet. cyl (%)	Fixed	Remarks
	13.5	800	46.2 ~ 48.4	± 2.5	Rack	Basic
H	Approx. 9.9	365	8.1 ~ 10.3	± 15	Rack	
A	R ₁ (13.5)	800	46.3 ~ 48.3	—	Lever	Basic Boost press. Above 400 mmHg
B	R ₁ (13.5)	1,000	(46.7 ~ 50.7)	—	Lever	Boost press. Above 400 mmHg
C	R ₁ - 0.8	400	(34.2 ~ 38.2)	—	Lever	Boost press. 0 mmHg

5. Timing Advance Specification :

Pump Speed (r.p.m.)	Below 550	500	700	1,050		
Advance Angle (deg)	Start	Below 0.5	Below 1.0	1.2 ~ 2.2	Finish 7.0 ~ 8.0	

3. GOVERNOR ADJUSTMENT

(1) Full speed

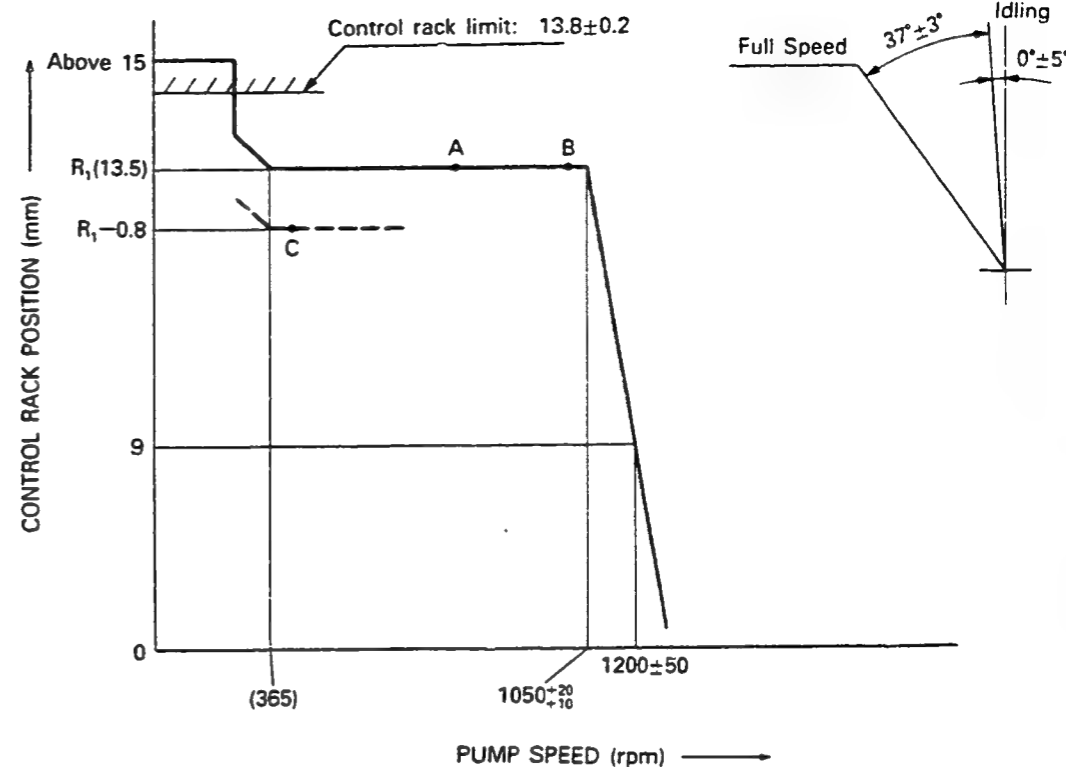

(2) Idling

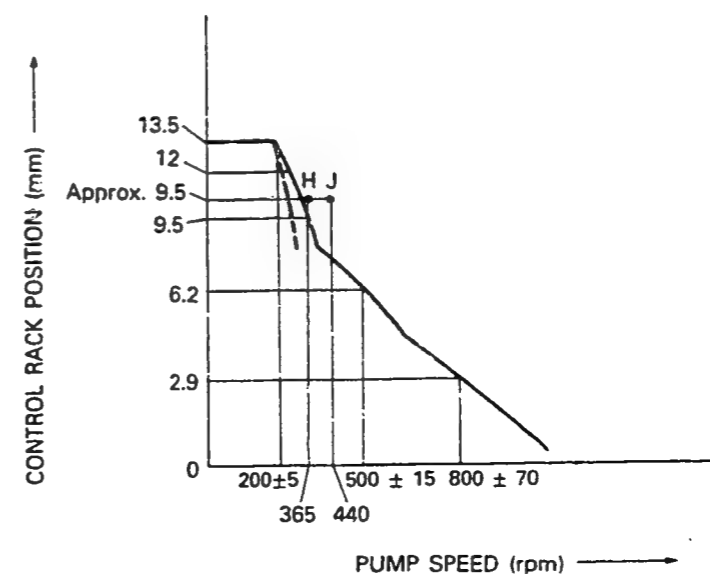

DIESEL KIKI CO. LTD.
 Service Department

3-6-7 SHIBUYA, SHIBUYA-KU, TOKYO 150, JAPAN
 Tel (03) 400-1551 Fax (03) 499-4115

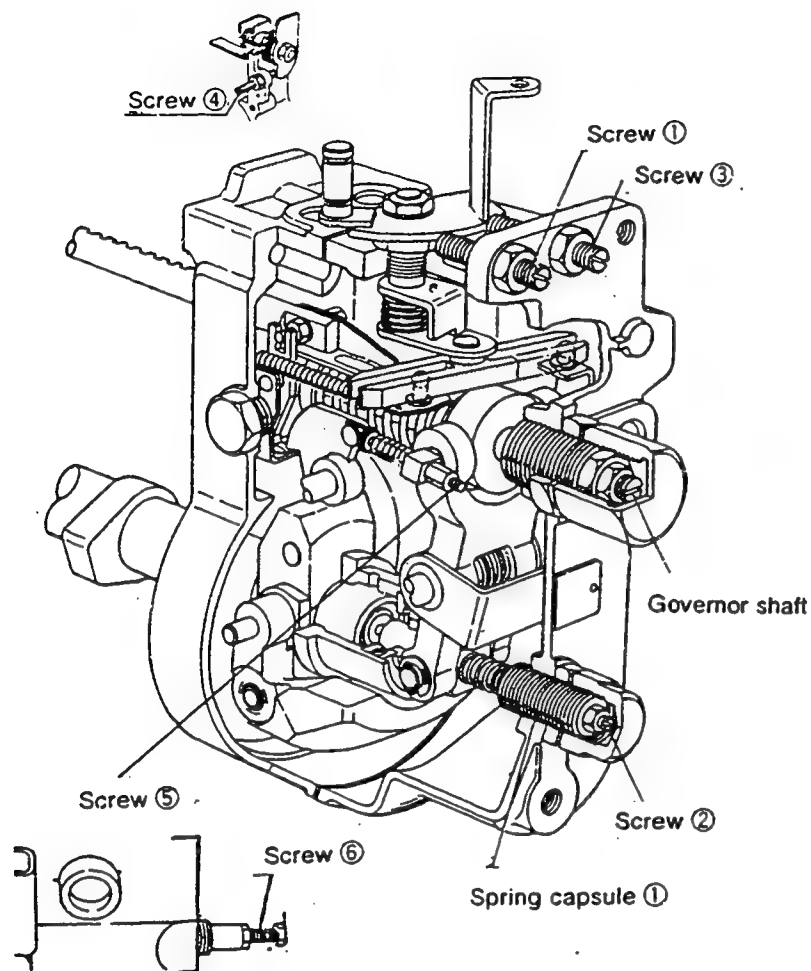

■ Idling Adjustment

Item	Pump Speed (rpm)	Rack Position (mm)	Remarks
Idling Lever Position: Temporary Setting	80 - 100	13.5	• Adjust using screw ①
Idling Position Setting	195 - 205	12.0	• Adjust using spring capsule ①.
	365	9.5	• Adjust shim ① inside the spring capsule.
Governor Spring Contact Adjustment	485 - 515	6.2	• Adjust the governor shaft position.
	730 - 870	2.9	• Confirm
Setting the Idling Lever Position	365	Approx. 9.5	• Adjust using screw ①.
	—	—	• Confirm the control lever angle (-5° ~ 5°)

■ Full Load Adjustment (Torque Cam No. 89)

Item	Pump Speed (rpm)	Rack Position (mm)	Remarks
Full Speed Lever Position: Temporary Setting	1060 - 1070	R ₁ (13.5)	• Adjust using screw ③. (Do not enter governor control range)
Full Load Position Adjustment	800	13.5	• Adjust using screw ④.
Torque Cam Position Adjustment	(365)	R ₁ (13.5)	• Adjust using screw ⑤.
	800	R ₁ (13.5)	• Confirm
			• Confirm
			• Confirm
			• Confirm
			• Confirm
			• Confirm
Confirm injection quantity at pints A to C.			
Maximum Speed control Adjustment	1060 - 1070	R ₁ + 0.3	• Adjust using screw ③.
	1200 - 1250	9.0	• Confirm
	—	—	• After adjustment, confirm that the control lever angle is 35° ~ 45°.
Confirming Excess Fuel Limit for Engine Starting	440	Approx. 9.5	• Set the control lever at point J.
	0	13.5	• Confirm • Move the control lever to the "full-speed" position and then confirm the control rack position.
Confirm the Black Smoke Limit			Fix the control lever at point H. Then, operate the pump at (365) rpm. Confirm that the control rack does not move beyond R ₁ (13.5) mm. When the control lever is moved to the "full-speed" position again increase the pump speed and confirm that the control rack starts to move from a pump speed of rpm.
Rack Limiter Adjustment	0	13.6 - 14.0	• Fix the control rack using screw.
	Measure the depth of the control rack cap. Then, adjust screw ⑥ so that it equals the depth of the rack cap and install the rack cap. Confirm injection quantity at point I.		

■ Boost Compensator Adjustment

- Maintain the pump speed at 400 rpm and fix the control lever in the full load position.
- In this condition, use calipers to measure the dimensions "L" of the pushrod from the end face of the spacer.
(Inspection: 23.5 to 24.5 mm)

- Timing Setting
At No. 1 plunger's beginning of injection position.
B.T.D.C.: 20°

Item	Boost press. (mmHg)	Rack Position (mm)	Remarks
Setting the Boost Compensator Spring Force	80 ~ 115	$R_1 - 0.8$	• Adjust using screw ⑦.
Boost Compensator Spring Adjustment Boost compensator stroke: 0.8 mm	0	$R_1 - 0.8$	• Adjust using screw ⑦.
	80 ~ 115 210 ~ 260	$R_1 - 0.8$ $R_1 (13.5)$	• Confirm • Confirm

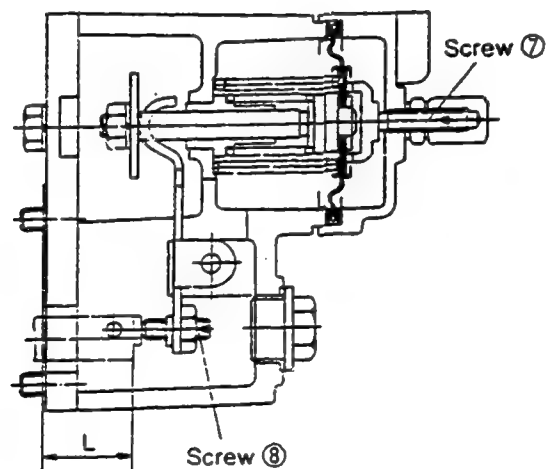
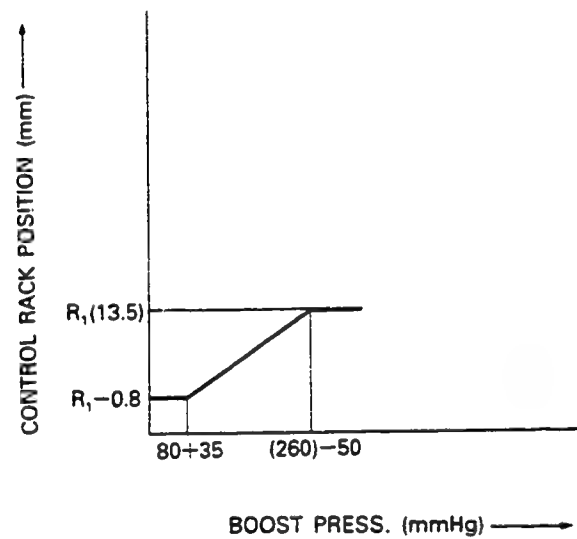
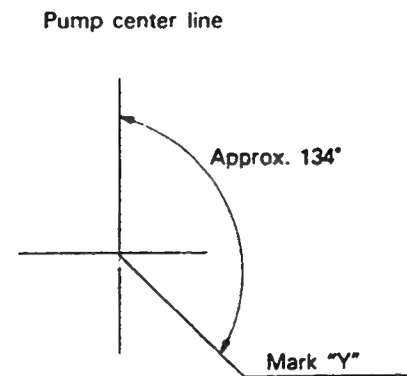

INJ. PUMP CALIBRATION DATA

ENGINE MODEL SD33T

BOSCH No. 9 400 610 067 1/6
 DKKC No. 101641 - 9190
 Date : 28, Oct. 1988
 Company : NISSAN DIESEL
 No. 16713-L6002

D - 4

101641 - 9190 2/6

Injection pump : PES6A Governor : EP/RLD Timing device : EP/SCD
 101064-9030 105931-2940 105622-0680

1. Test Conditions :

Pump rotation : clockwiseviewed from drive side

Nozzle & Nozzle Holder Ass'y : 105780-0000 Nozzle Holder : 105780-2080
 (BOSCH Type No. DN12SD12T) (BOSCH Type No. EF8511/9A)
 Nozzle opening pressure : 175 kg/cm² Transfer pump pressure : 1.6 kg/cm²

Injection pipe :
 Inner Dia. 2 mm x Outer Dia. 6 mm — Length 600 mm

Test Oil : ISO4113 or SAE Standard Test Oil (SAE J967d) Oil Temp. : 40 °C

Overflow valve opening pressure : kg/cm²

2. Injection Timing :

Pre-stroke : No. 1 Plunger 2.3 ± 0.05 mm

Note : Adjust with control rod position of mm

Injection order : 1 - 4 - 2 - 6 - 3 - 5 (interval: 60° ± 30')

Plungers are numbered from the Drive side.

Tappet clearance : Bolt adjustment type ; More than 0.3 mm for all cylinders.

4. Injection Quantity :

Adjusting Point	Rod Position (mm)	Pump Speed (r.p.m.)	Injection Q'ty (cc/1000 strokes)	Max. var bet. cyl (%)	Fixed	Remarks
	12	1,150	37.3 - 39.5	± 2.5	Rack	Basic
H	Approx. 9.05	365	5.1 - 7.3	± 15	Rack	
A	R ₁ (12)	1,150	37.4 - 39.4	—	Lever	Basic Boost press. Above 220 mmHg
B	R ₁ + 0.05	950	35.8 - 39.8	—	Lever	
C	R ₁ - 0.1	500	32.6 - 36.6	—	Lever	

5. Timing Advance Specification :

Pump Speed (r.p.m)	500	700	1,100	1,200			
Advance Angle (deg)	Below 0.5	Below 1.0	1.7 - 2.7	2.0 - 3.0	Finish (7.5)		

3. GOVERNOR ADJUSTMENT

(1) Full speed

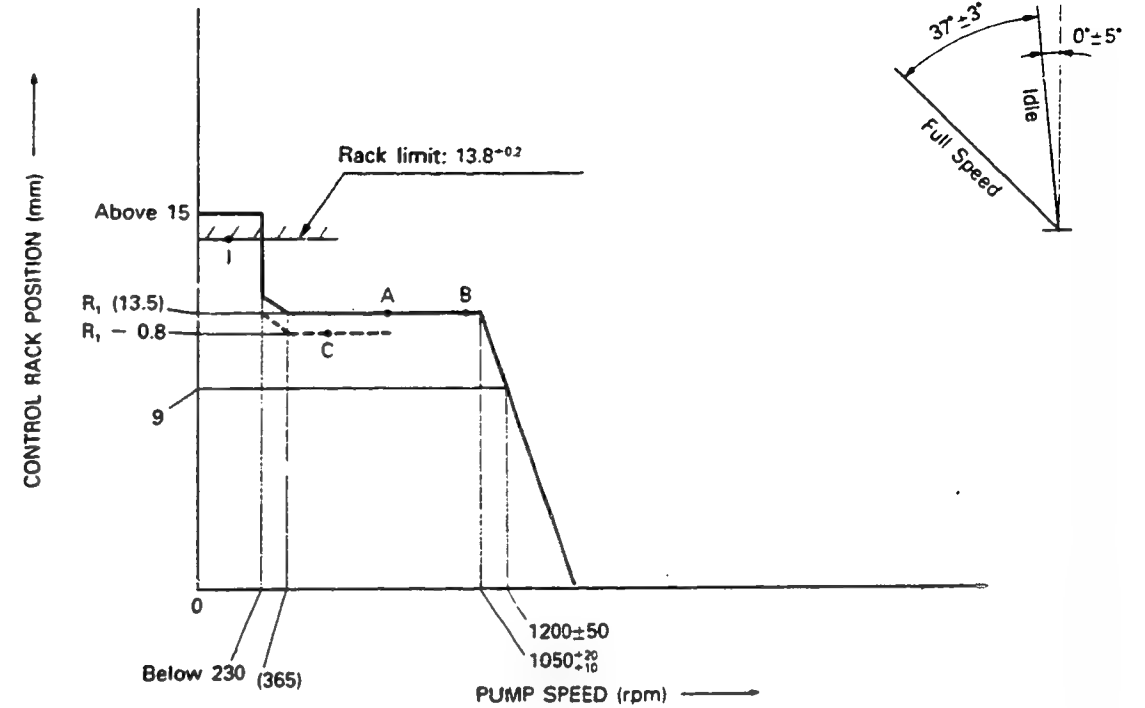

(2) Idling

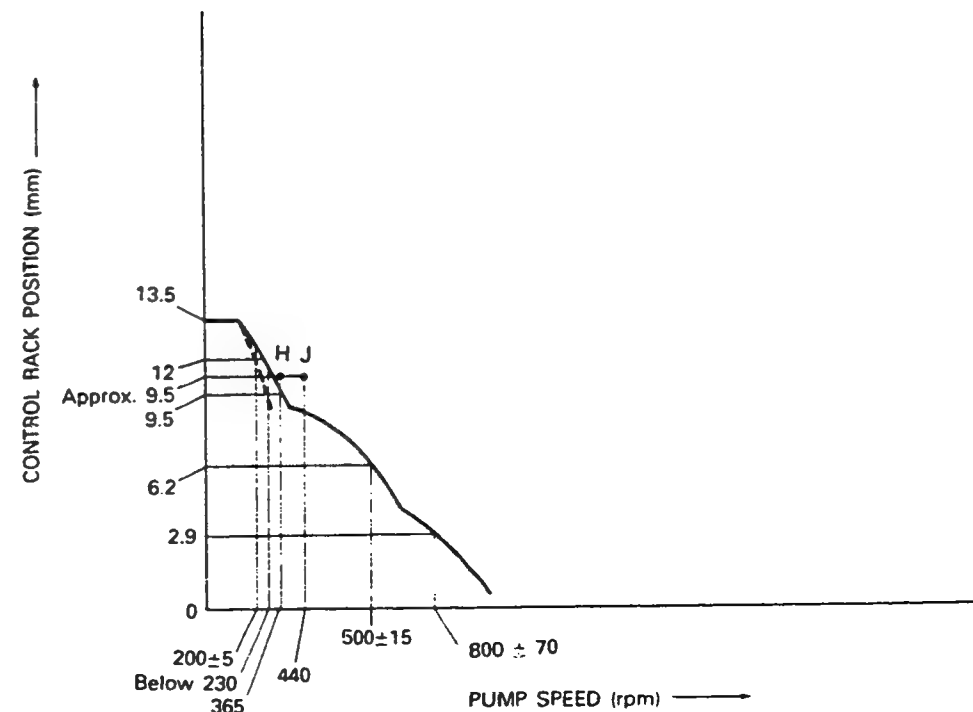

DIESEL KIKI CO., LTD. 3-6-7 SHIBUYA, SHIBUYA-KU, TOKYO 150, JAPAN
 Sen 3 Department Tel (03) 400-1551 Fax (03) 490-4115

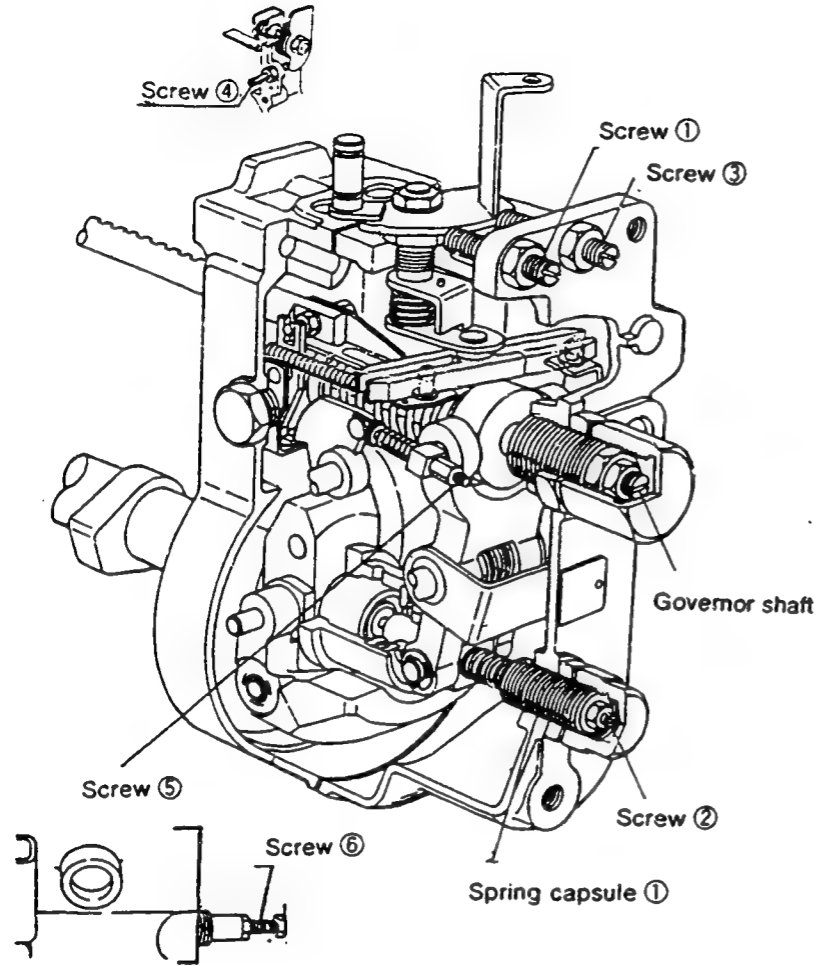

■ Idling Adjustment

Item	Pump Speed (rpm)	Rack Position (mm)	Remarks
Idling Lever Position: Temporary Setting	80 ~ 100	13.5	• Adjust using screw 1
Idling Position Setting	195 ~ 205	12.0	• Adjust using spring capsule 1.
	365	9.5	• Adjust shim 1 inside the spring capsule.
Governor Spring Contact Adjustment	485 ~ 515	6.2	• Adjust the governor shaft position.
	730 ~ 870	2.9	• Confirm
Setting the Idling Lever Position	365	Approx. 9.5	• Adjust using screw 1.
	—	—	• Confirm the control lever angle (-5° ~ 5°)

■ Full Load Adjustment (Torque Cam No. 89)

Item	Pump Speed (rpm)	Rack Position (mm)	Remarks
Full Speed Lever Position: Temporary Setting	1060 ~ 1070	R ₁ (13.5)	• Adjust using screw 3. (Do not enter governor control range)
Full Load Position Adjustment	800	13.5	• Adjust using screw 4.
Torque Cam Position Adjustment	(365)	R ₁ (13.5)	• Adjust using screw 3.
	800	R ₁ (13.5)	• Confirm
			• Confirm
			• Confirm
			• Confirm
			• Confirm
			• Confirm
Confirm injection quantity at points A to C.			
Maximum Speed control Adjustment	1060 ~ 1070	R ₁ + 0.3	• Adjust using screw 3.
	1200 ~ 1250	9.0	• Confirm
	—	—	• After adjustment, confirm that the control lever angle is 35° ~ 45°.
Confirming Excess Fuel Limit for Engine Starting	440	Approx. 9.5	• Set the control lever at point J.
	0	13.5	• Confirm
			• Move the control lever to the "full-speed" position and then confirm the control rack position.
Confirm the Black Smoke Limit	Fix the control lever at point H. Then, operate the pump at (365) rpm. Confirm that the control rack does not move beyond R ₁ (13.5) mm. When the control lever is moved to the "full-speed" position again increase the pump speed and confirm that the control rack starts to move from a pump speed of rpm.		
Rack Limiter Adjustment	0	13.6 ~ 14.0	• Fix the control rack using screw Part No. 157954-3700
	Measure the depth of the control rack cap. Then, adjust screw 6 so that it equals the depth of the rack cap and install the rack cap. Confirm injection quantity at point I.		

D - 6

■ Boost Compensator Adjustment

- Maintain the pump speed at 400 rpm and fix the control lever in the full load position.
- In this condition, use calipers to measure the dimensions "L" of the pushrod from the end face of the spacer.
(Inspection: 23.5 to 24.5 mm)

■ Timing Setting

At No. 1 plunger's beginning of injection position.
B.D.T.D.: 20°

Item	Boost press. (mmHg)	Rack Position (mm)	Remarks
Setting the Boost Compensator Spring Force	80 ~ 115	$R_1 - 0.8$	• Adjust using screw 7.
Boost Compensator Spring Adjustment	0	$R_1 - 0.8$	• Adjust using screw 8.
Boost compensator stroke: 0.8 mm	80 ~ 115	$R_1 - 0.8$	• Confirm
	210 ~ 260	$R_1 (13.5)$	• Confirm

Pump center line

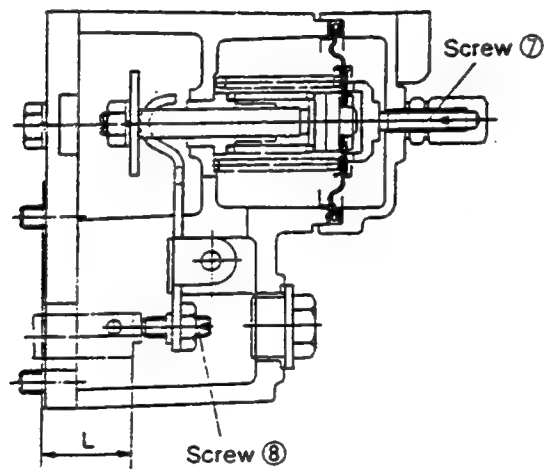
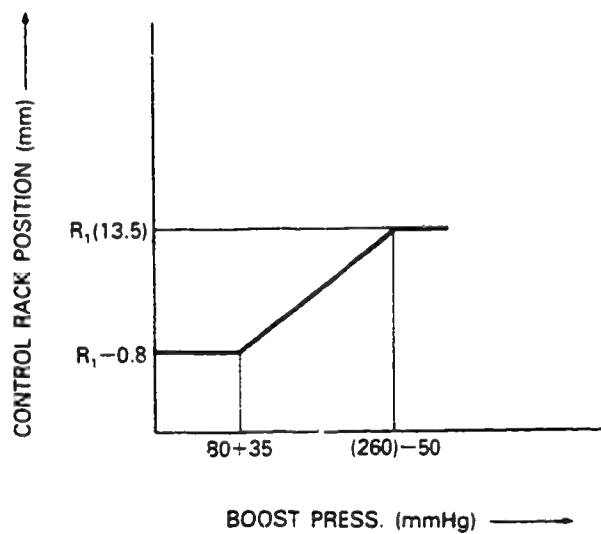
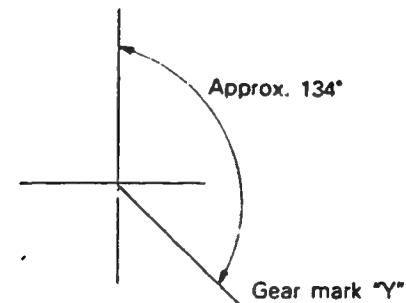

INJ. PUMP CALIBRATION DATA

Distributor-type

TEST OIL:
ISO 4113 or
SAE J967d

ENGINE MODEL : XA

BOSCH No. 9 460 610 320
DKKC No. 104740 - 0102
Date : 28, Oct. 1988
Company : MAZDA
No. 4846 13 800B

D - 7

Injection pump No.: 104640-0102 [NP-VE4/10F1200RNP54]

Pump rotation : clockwise-viewed from drive side

For Test Condition see
Microfiche No. WP-210 (N-16)

Pre-stroke : — mm

1. Setting		Pump speed (rpm)	Settings	Charge air press (mmHg)	Difference in delivery (cc)
1-1	Timing device travel	1,000	2.5 ~ 3.0 (mm)		
1-2	Supply pump pressure	1,000	4.0 ~ 4.6 (kg/cm ²)		
1-3	Full load delivery without charge air pressure	1,000	37.6 ~ 38.6 (cc/1,000st)		2.5
	Full load delivery with charge air pressure		(cc/1,000st)		
1-4	Idle speed regulation	300	6.2 ~ 10.2 (cc/1,000st)		2.0
1-5	Start	100	Above 80 (cc/1,000st)		
1-6	Full-load speed regulation	1,325	12.8 ~ 18.8 (cc/1,000st)		
1-7					
1-8					

2. Test Specifications

2-1	Timing device	N = rpm mm	1,000 2.5 ~ 3.1	1,200 3.5 ~ 4.7
2-2	Supply pump	N = rpm kg/cm ²	500 2.2 ~ 2.8	1,000 4.0 ~ 4.6
2-3	Overflow delivery	N = rpm cc/10s	1,000 35.0 ~ 78.0	
2-4	Fuel injection quantities			
	Speed control lever position	Pump speed (rpm)	Fuel delivery (cc/1,000st)	Charge air press(mmHg) Difference in delivery (cc)
	Full speed position	1,000	37.1 ~ 39.1	
		500	36.6 ~ 40.6	
		1,200	36.6 ~ 40.6	
		1,325	12.8 ~ 18.8	
		1,450	Below 5.0	
	Switch OFF	300	0	
	Idling position	300	6.2 ~ 10.2	
		Below 400	0	
2-5	Solenoid	Max. cut-in voltage: 8 V Test voltage: 12 ~ 14 V		

3. Dimensions

K	3.2 ~ 3.4	mm
KF	5.7 ~ 5.9	mm
MS	1.5 ~ 1.7	mm
BCS	—	mm
Control lever angle		
α	6.0 ~ 14.0	deg
A	—	mm
β	31.0 ~ 41.0	deg
B	—	mm
γ	—	deg
C	—	mm



DIESEL KIKI

DIESEL KIKI CO., LTD.

Service Department

3-6-7 SHIBUYA SHIBUYA-KU TOKYO 150 JAPAN

Tel (03) 400-1551 Fax (03) 499-4115

INJ. PUMP CALIBRATION DATA

Distributor-type

TEST OIL:
ISO 4113 or
SAE J9C7d

ENGINE MODEL : HA

Injection pump No.: 104640-0201

[NP-VE4/10F1250RN²122]

BOSCH No. 9 460 610 213
DKKC No. 104740 - 0201
Date : 28, Oct. 1988
Company : MAZDA
No. 4834 13 800A

D - 8

Pump rotation : clockwise-viewed from drive side

For Test Condition see
Microfiche No. WP-210 (N-16)

Pre stroke : 0.18 - 0.22 mm

1. Setting		Pump speed (rpm)	Settings	Charge air press (mmHg)	Difference in delivery (cc)
1-1	Timing device travel	1,000	2.0 - 2.4 (mm)		
1-2	Supply pump pressure	1,000	4.0 - 4.6 (kg/cm ²)		
1-3	Full load delivery without charge air pressure	1,000	53.1 - 54.1 (cc/1,000st)		3.5
	Full load delivery with charge air pressure		(cc/1,000st)		
1-4	Idle speed regulation	315	10.8 - 14.8 (cc/1,000st)		2.5
1-5	Start	100	Above 78.0 (cc/1,000st)		
1-6	Full-load speed regulation	1,380	12.8 - 18.8 (cc/1,000st)		
1-7					
1-8					

2. Test Specifications

2-1	Timing device	N = rpm mm	1,000 1.9 - 2.5	1,250 3.1 - 4.3	
2-2	Supply pump	N = rpm kg/cm ²	500 2.3 - 2.9	1,000 4.0 - 4.6	1,250 4.8 - 5.4
2-3	Overflow delivery	N = rpm cc/10s	1,000 53.0 - 97.0		
2-4	Fuel injection quantities				
	Speed control lever position	Pump speed (rpm)	Fuel delivery (cc/1,000st)	Charge air press(mmHg)	Difference in delivery (cc)
	Full speed position	1,000	52.6 - 54.6		
		500	45.6 - 49.6		
		1,250	51.6 - 55.6		
		1,380	12.8 - 18.8		
		1,430	Below 6.0		
	Switch OFF	315	0		
	Idling position	315	10.8 - 14.8		
		Below 620	0		
2-5	Solenoid	Max. cut-in voltage: 8 V Test voltage: 12 - 14 V			

3. Dimensions

K	3.2 - 3.4	mm
KF	5.7 - 5.9	mm
MS	1.7 - 1.9	mm
BCS	-	mm
Control lever angle		
α	19.0 - 29.0	deg
A	4.4 - 9.6	mm
β	39.0 - 49.0	deg
B	11.8 - 15.8	mm
γ	-	deg
C	-	mm



DIESEL KIKI CO., LTD.
Service Department

3-6-7 SHIBUYA, SHIBUYA-KU TOKYO 150 JAPAN
Tel (03) 400-1551 Fax (03) 499-4115

INJ. PUMP CALIBRATION DATA

Distributor-type

TEST OIL:
ISO 4113 or
SAE J967d

ENGINE MODEL : 4D56

BOSCH No. 9 460 610 275
DKKC No. 104740 - 3671
Date : 28, Oct 1988
Company : MITSUBISHI
No. MD106444

D - 9

104740 - 3671

Injection pump No: 104640 - 3371 (NP-VE4/10F2100RNP460)

Pump rotation : clockwise-viewed from drive side

Pre-stroke : - mm

For Test Condition see
Microfiche No.WP-210(N16)

1. Setting	Pump speed (rpm)	Settings	Charge air press(mmHg)	Difference in delivery(cc)
1-1 Timing device travel	1,250	T=3.5~ 3.9 (mm)		
1-2 Supply pump pressure	1,250	4.5~ 5.1 (kg/cm ²)		
1-3 Full load delivery without charge air pressure	1,250	45.3~46.3 (cc/1,000st)		3.0
Full load delivery with charge air pressure		(cc/1,000st)		
1-4 Idle speed regulation	375	6.5~ 9.5 (cc/1,000st)		2.0
1-5 Start	100	63.0~83.0 (cc/1,000st)		
1-6 Full-load speed regulation	2,550	15.1~21.1 (cc/1,000st)		4.0
1-7 Load-timer adjustment	1,250	T=0.6± 0.2 (mm)		
1-8				

2. Test Specifications

2-1 Timing device	N = rpm	500	750	1,250	2,100
	mm	0.6~ 1.8	1.4~ 2.6	3.3~ 4.1	6.6~ 7.8
2-2 Supply pump	N = rpm	600	1,250	2,100	
	kg/cm ²	2.9~ 3.5	4.5~ 5.1	6.5~ 7.1	
2-3 Overflow delivery	N = rpm	1,250			
	cc/10s	48.0~92.0			

2-4 Fuel injection quantities

Speed control lever position	Pump speed (rpm)	Fuel delivery (cc/1,000st)	Charge air press(mmHg)	Difference in delivery(cc)
Full speed position	1,250	44.8~46.8		
	600	42.3~46.3		
	2,100	37.2~41.2		
	2,550	14.6~21.6		
	2,900	Below 5.0		

Switch OFF	375	0		
Idling position	600	Below 3.0		
	375	6.0~10.0		

2-5 Solenoid Max cut-in voltage : 8 V
Test voltage : 12~14 V

3. Dimensions

K	3.2~3.4	mm
KF	5.7~5.9	mm
MS	1.1~1.3	mm
BCS		mm

Control lever angle

α	19.0~27.0	deg
A	12.4~17.8	mm
β	41.0~51.0	deg
B	12.1~16.1	mm
γ		deg
C		mm

LOAD TIMER ADJUSTMENT

1) Adjustment

① Fix the control lever in the position satisfying the following conditions.

Boost Pressure :	-	mmHg
Pump Speed :	1,250	rpm
Fuel Injection Quantity :	35.7±1	cc/1000st

② With the control lever positioned as described in (1) above, adjust the governor sleeve so that the Timer Stroke conforms to the specified values (page 1/2)

2) Confirmation of Timer Characteristics

Fix the control lever in the position satisfying the following conditions, and confirm the Timer Stroke.

Pump speed (rpm)	Control lever position		Specified Values	
	Fuel Injection Quantity(cc/1000st)	Boost pressure (mmHg)	Timer stroke (mm)	Timer stroke reduction value (mm)
1,250	34.7~36.7	--	(3.1)	0.2~1.0
1,250	26.7~29.7	--	(2.3)	0.8~2.0

INJ. PUMP CALIBRATION DATA

Distributor-type

TEST OIL:
I S O 4113 or
S A E J967d

ENGINE MODEL : 4D56

BOSCH No. 9 460 610 276
DKKC No. 104740 - 3681
Date : 28. Oct. 2988
Company : MITSUBISHI
No. MD106426

D = 10

104740 - 3681

Injection pump No: 104640 - 3381 [IP-VE4/10F2100RNP461]

For Test Condition see
Microfiche No.WP-210(N16)

Pump rotation : clockwise-viewed from drive side
Pre-stroke : - mm

1. Setting	Pump speed (rpm)	Settings	Charge air press(mmHg)	Difference in delivery(cc)
1-1 Timing device travel	1,250	T=3.5~ 3.9 (mm)		
1-2 Supply pump pressure	1,250	4.5~ 5.1 (kg/cm ²)		
1-3 Full load delivery without charge air pressure	1,250	45.3~46.3 (cc/1,000st)		3.0
Full load delivery with charge air pressure		(cc/1,000st)		
1-4 idle speed regulation	375	6.5~ 9.5 (cc/1,000st)		2.0
1-5 Start	100	63.0~83.0 (cc/1,000st)		
1-6 Full-load speed regulation	2,550	15.1~21.1 (cc/1,000st)		4.0
1-7 Load-timer adjustment	1,250	T=0.6± 0.2 (mm)		
1-8				

2. Test Specifications

2-1 Timing device	N = rpm	500	750	1,250	2,100
	mm	0.6~ 1.8	1.4~ 2.6	3.3~ 4.1	6.6~ 7.8
2-2 Supply pump	N = rpm	600	1,250	2,100	
	kg/cm ²	2.9~ 3.5	4.5~ 5.1	6.5~ 7.1	
2-3 Overflow delivery	N = rpm	1,250			
	cc/10s	48.0~92.0			

2-4 Fuel injection quantities

Speed control lever position	Pump speed (rpm)	Fuel delivery (cc/1,000st)	Charge air press(mmHg)	Difference in delivery(cc)
Full speed position	1,250	44.8~46.8		
	600	42.3~46.3		
	2,100	37.2~41.2		
	2,550	14.6~21.6		
	2,900	Below 5.0		

Switch OFF	375	0		
Idling position	600	Below 3.0		
	375	6.0~10.0		

2-5 Max.cut-in voltage : 8 V
Solenoid Test voltage : 12~14 V

3. Dimensions

K	3.2~3.4	mm
KF	5.7~5.9	mm
MS	1.1~1.3	mm
BCS		mm

Control lever angle

α	19.0~27.0	deg
A	12.4~17.8	mm
β	41.0~51.0	deg
B	12.1~16.1	mm
Y		deg
C		mm

LOAD TIMER ADJUSTMENT

1) Adjustment

① Fix the control lever in the position satisfying the following conditions.

Boost Pressure :	-	mmHg
Pump Speed :	1,250	rpm
Fuel Injection Quantity :	35.7±1	cc/1000st

② With the control lever positioned as described in ① above, adjust the governor sleeve so that the Timer Stroke conforms to the specified values (page 1/2)

2) Confirmation of Timer Characteristics

Fix the control lever in the position satisfying the following conditions, and confirm the Timer Stroke.

Control lever position			Specified Values	
Pump speed (rpm)	Fuel Injection Quantity(cc/1000st)	Boost pressure (mmHg)	Timer stroke (mm)	Timer stroke reduction value (mm)
1,250	34.7~36.7	---	(3.1)	0.2~1.0
1,250	26.7~29.7	---	(2.3)	0.8~2.0



DIESEL KIKI CO. LTD.
Service Department

3-6-7 SHIBUYA, SHIBUYA-KU, TOKYO 150, JAPAN
Tel (03) 400-1551 Fax (03) 499-4115

INJ. PUMP CALIBRATION DATA

Distributor-type

BOSCH No. 9 460 610 277
 DKKC No. 104740 - 3691
 Date : 28. Oct. 2988
 Company : MITSUBISHI
 No. MD109319

D - 11

104740 - 3691

TEST OIL:
 I S O 4113 or
 S A E J967d

ENGINE MODEL : 4D56

For Test Condition see
 Microfiche No.WP-210(N16)

Injection pump No: 104640 - 3381 [NP-VE4/10F2100RNP461]

Pump rotation : clockwise-viewed from drive side

Pre-stroke : - mm

LOAD TIMER ADJUSTMENT

1) Adjustment

① Fix the control lever in the position satisfying the following conditions.

Boost Pressure : - mmHg
 Pump Speed : 1,250 rpm
 Fuel Injection Quantity : 35.7±1 cc/1000st

② With the control lever positioned as described in ① above, adjust the governor sleeve so that the Timer Stroke conforms to the specified values (page 1/2)

2) Confirmation of Timer Characteristics

Fix the control lever in the position satisfying the following conditions, and confirm the Timer Stroke

Control lever position			Specified Values	
Pump speed (rpm)	Fuel Injection Quantity(cc/1000st)	Boost pressure (mmHg)	Timer stroke (mm)	Timer stroke reduction value (mm)
1,250	34.7~36.7	---	(3.1)	0.2~1.0
1,250	26.7~29.7	---	(2.3)	0.2~2.0

3. Dimensions

K 3.2~3.4 mm
 KF 5.7~5.9 mm
 MS 1.1~1.3 mm
 BCS --- mm

Control lever angle

α 19.0~27.0 deg
 A 12.4~17.8 mm
 β 41.0~51.0 deg
 B 12.1~16.1 mm
 γ --- deg
 C --- mm

1. Setting	Pump speed (rpm)	Settings	Charge air press(mmHg)	Difference in delivery(cc)
1-1 Timing device travel	1,250	T=3.5~3.9 (mm)		
1-2 Supply pump pressure	1,250	4.5~5.1 (kg/cm ²)		
1-3 Full load delivery without charge air pressure	1,250	45.3~46.3 (cc/1,000st)		3.0
Full load delivery with charge air pressure		(cc/1,000st)		
1-4 Idle speed regulation	375	6.5~9.5 (cc/1,000st)		2.0
1-5 Start	100	63.0~63.0 (cc/1,000st)		
1-6 Full-load speed regulation	2,550	15.1~21.1 (cc/1,000st)		4.0
1-7 Load-timer adjustment	1,250	T=0.6±0.2 (mm)		
1-8				

2. Test Specifications

2-1 Timing device	N = rpm	500	750	1,250	2,100
	mm	0.6~1.8	1.4~2.6	3.3~4.1	6.6~7.8
2-2 Supply pump	N = rpm	600	1,250	2,100	
	kg/cm ²	2.9~3.5	4.5~5.1	6.5~7.1	
2-3 Overflow delivery	N = rpm	1,250			
	cc/10s	48.0~92.0			

2-4 Fuel injection quantities

Speed control lever position	Pump speed (rpm)	Fuel delivery (cc/1,000st)	Charge air press(mmHg)	Difference in delivery(cc)
Full speed position	1,250	44.8~46.8		
	600	42.3~46.3		
	2,100	37.2~41.2		
	2,550	14.6~21.6		
	2,900	Below 5.0		

Switch OFF	375	0		
Idling position	600	Below 3.0		
	375	6.0~10.0		

2-5 Solenoid Max.cut-in voltage : 8 V
 Test voltage : 12~14 V



DIESEL KIKI CO. LTD.
 Service Department

3-6-7 SHIBUYA, SHIBUYA-KU, TOKYO 150, JAPAN
 Tel (03) 400-1551 Fax (03) 499-4115

INJ. PUMP CALIBRATION DATA

Distributor-type

TEST OIL:
ISO 4113 or
SAE J967d

ENGINE MODEL : SD23

Injection pump No.: 104640-4550 [NP-VE4/10F2150RNP301]

BOSCH No. 9 460 610 251
DKKC No. 104740 - 4560
Date : 28, Oct. 1988
Company : NISSAN DIESEL
No. 1670009 W05

D - 12

Pump rotation : clockwise-viewed from drive side

For Test Condition see
Microfiche No. WP-210 (N-16)

Pre-stroke : 0.18 ~ 0.22 mm

1. Setting	Pump speed (rpm)	Settings	Charge air press (mmHg)	Difference in delivery (cc)
1-1 Timing device travel	1,400	3.0 - 3.4 (mm)		
1-2 Supply pump pressure	1,700	5.6 - 6.2 (kg/cm ²)		
1-3 Full load delivery without charge air pressure	1,000	37.6 - 38.6 (cc/1,000st)		3.0
Full load delivery with charge air pressure		(cc/1,000st)		
1-4 Idle speed regulation	300	4.3 - 8.3 (cc/1,000st)		2.0
1-5 Start	100	55.0 - 90.0 (cc/1,000st)		
1-6 Full-load speed regulation	2,300	14.7 - 20.7 (cc/1,000st)		
1-7				
1-8				

2. Test Specifications

2-1 Timing device	N = rpm mm	1,400 2.9 ~ 3.5	1,700 3.8 ~ 5.0	2,150 5.6 ~ 6.8	
2-2 Supply pump	N = rpm kg/cm ²	600 3.0 ~ 3.6	1,700 5.6 ~ 6.2	2,150 6.8 ~ 7.4	
2-3 Overflow delivery	N = rpm cc/10s	1,000 8.0 ~ 52.0			
2-4 Fuel injection quantities	Speed control lever position	Pump speed (rpm)	Fuel delivery (cc/1,000st)	Charge air press (mmHg)	Difference in delivery (cc)
Full speed position		1,000	37.1 - 39.1		
		600	32.9 - 36.9		
		2,150	33.4 - 37.4		
		2,300	14.2 - 21.2		
		2,450	Below 5.0		
Switch OFF		300	0		
Idling position		300	4.3 - 8.3		
		350	Below 3.0		
2-5 Solenoid	Max. cut-in voltage: 12 V Test voltage: V				

3. Dimensions

K	3.2 - 3.4	mm
KF	5.65 - 5.85	mm
MS	1.4 - 1.6	mm
BCS	-	mm

Control lever angle

α	21.0 - 29.0	deg
A	4.0 - 9.2	mm
β	41.0 - 51.0	deg
B	12.1 - 16.1	mm
γ	-	deg
C	-	mm



DIESEL KIKI CO., LTD.
Service Department

3-6-7 SHIBUYA, SHIBUYA-KU, TOKYO 150, JAPAN
Tel (03) 400-1531 Fax (03) 499-4115

INJ. PUMP CALIBRATION DATA

Distributor-type

BOSCH No. 9 460 610 323 1/2
 DKKC No. 104741 - 1984
 Date : 28, Oct. 1988
 Company : ISUZU
 No. 894139 7412

D - 13

104741-1084 2/2

TEST OIL:
 ISO 4113 or
 SAE J967d

ENGINE MODEL : 4JA1-AG

Injection pump No.: 104641-1044 [NP-VE4/11F1900LNP283]

Pump rotation : Counter clockwise-viewed from drive side For Test Condition see Microfiche No. WP-210 (N-16)

Pre-stroke : 0.43 - 0.47 mm

Note:
 ○ If there is no designation in the specifications Solenoid Timer ON - OFF position, then the position should be regarded OFF.

1. Setting	Pump speed (rpm)	Settings	Charge air press (mmHg)	Difference in delivery (cc)
1-1 Timing device travel	1,500	2.1 ~ 2.5 (mm)		
1-2 Supply pump pressure	1,500	5.0 ~ 5.4 (kg/cm ²)		
1-3 Full load delivery without charge air pressure	1,000	39.0 ~ 40.0 (cc/1,000st)		3.0
Full load delivery with charge air pressure		(cc/1,000st)		
1-4 Idle speed regulation	390	5.5 ~ 9.5 (cc/1,000st)		2.0
1-5 Start	100	75.0 ~ 105.0 (cc/1,000st)		
1-6 Full-load speed regulation	2,100	13.1 ~ 19.1 (cc/1,000st)		4.5
1-7 Aneroid compensator	1,000	Decrease: 3.2 ~ 5.5 (cc/1000st)	-164 ± 5	
1-8				

2. Test Specifications	Solenoid timer	ON	OFF
2-1 Timing device	N = rpm mm	450 ~ 650 0.5	1,200 ~ 1,300 0.5
2-2 Supply pump	N = rpm kg/cm ²	1,000 3.1 ~ 3.7	1,500 5.0 ~ 5.4
2-3 Overflow delivery	N = rpm cc/10s	1,500 53.0 ~ 97.0	1,950 6.4 ~ 7.0

Speed control lever position	Pump speed (rpm)	Fuel delivery (cc/1,000st)	Charge air press(mmHg)	Difference in delivery (cc)
Full speed position	1,000	38.5 ~ 40.5		
	500	32.6 ~ 39.6		
	700	33.1 ~ 37.1		
	1,350	40.2 ~ 44.2		
	1,800	36.4 ~ 41.4		
	2,000	29.2 ~ 35.2		
	2,100	12.6 ~ 19.6		
	2,300	Below 5.0		
Switch OFF	390	0		
Idling position	390	5.5 ~ 9.5		
	550	Below 3.0		
Aneroid compensator	1,000	Decrease: 2.5 ~ 6.2	-164 ± 5	
2-5 Solenoid	Max. cut-in voltage: 8 V			

3. Dimensions		
K	2.7 ~ 2.9	mm
KF	4.9 ~ 5.1	mm
MS	0.9 ~ 1.1	mm
BCS	—	mm
Control lever angle		
a	14.0 ~ 22.0	deg
A	2.5 ~ 7.6	mm
β	26.0 ~ 36.0	deg
B	7.4 ~ 11.2	mm
γ	—	deg
C	—	mm

INJ. PUMP CALIBRATION DATA

Distributor-type

TEST OIL:
ISO 4113 or
SAE J967d

ENGINE MODEL : 4JC1-PZ

Injection pump No.: 104641-1101 [NP-VE4/11F1050LNP365]

BOSCH No. 9 460 610 324
DKKC No. 104741 - 1181
Date : 28, Oct. 1988
Company : ISUZU
No. 894147 5451

D - 14

Pump rotation : Counter clockwise-viewed from drive side

For Test Condition see
Microfiche No. WP-210 (N-16)

Pre-stroke : 0.43 - 0.47 mm

1. Setting	Pump speed (rpm)	Settings	Charge air press (mmHg)	Difference in delivery (cc)
1-1 Timing device travel	1,100	1.4 ~ 1.8 (mm)		
1-2 Supply pump pressure	1,100	5.1 ~ 5.5 (kg/cm ²)		
1-3 Full load delivery without charge air pressure	800	31.3 ~ 32.3 (cc/1,000st)		3.0
Full load delivery with charge air pressure		(cc/1,000st)		
1-4 Idle speed regulation	700	14.0 ~ 16.0 (cc/1,000st)		2.0
1-5 Start	100	Above 70.0 (cc/1,000st)		
1-6 Full-load speed regulation	1,100	20.1 ~ 22.1 (cc/1,000st)		3.0
1-7				
1-8				

2. Test Specifications

2-1 Timing device	N = rpm mm	580 ~ 780 0.5	1,100 1.3 ~ 1.9
2-2 Supply pump	N = rpm kg/cm ²	700 4.0 ~ 4.6	1,100 5.1 ~ 5.5
2-3 Overflow delivery	N = rpm cc/10s	1,050 48.3 ~ 91.7	
2-4 Fuel injection quantities			
Speed control lever position	Pump speed (rpm)	Fuel delivery (cc/1,000st)	Charge air press(mmHg) Difference in delivery (cc)
Full speed position	800	30.8 ~ 32.8	
	700	30.4 ~ 35.4	
	900	28.2 ~ 32.2	
	1,000	27.7 ~ 31.7	
	1,050	25.5 ~ 30.5	
	1,100	19.6 ~ 22.6	
	1,150	2.9 ~ 9.9	
	1,200	Below 3.0	
Switch OFF	700	0	
Idling position	700	14.0 ~ 16.0	
	800	Below 3.0	
2-5 Solenoid	Max. cut-in voltage: 8 V Test voltage: 12 ~ 14 V		

3. Dimensions

K	2.7 ~ 2.9	mm
KF	4.9 ~ 5.1	mm
MS	2.0 ~ 2.2	mm
BCS	—	mm
Control lever angle		
α	3.0 ~ 11.0	deg
A	16.0 ~ 21.0	mm
β	4.0 ~ 14.0	deg
B	1.26 ~ 4.60	mm
γ	—	deg
C	—	mm



DIESEL KIKI CO., LTD.
Service Department

3-6-7 SHIBUYA, SHIBUYA-KU, TOKYO 150, JAPAN
Tel (03) 400-1551 Fax (03) 499-4115

INJ. PUMP CALIBRATION DATA

Distributor-type

TEST OIL:
I S O 4113 or
S A E J967d

ENGINE MODEL : S2

Injection pump No: 104648 - 0051 [NP-VE4/8F2125LNP138]

Pump rotation : Counter clockwise-viewed from drive side

Pre-stroke : - mm

1/3
BOSCH No. 9 460 610 216

DKKC No. 104748 - 0051

Date : 28, Oct. 1988

Company : MAZDA

No. S201 13 800C

For Test Condition see
Microfiche No.WP-210(N16)

D - 15

■ M-CSD Assembly and Adjustment

1) Fixing the M-CSD stopper

1. Fix the M-CSD assembly temporarily to the pump housing.
2. Turn the drive shaft at least two turns in the direction of pump rotation.
3. Turn the drive shaft slowly, and fix the drive shaft in a position where a load is applied (the point where the roller in the roller holder contacts the cam surface of the cam disc).
4. Move the CSD lever to the advance side.
5. Fix the CSD lever in the position where the ball pin at the tip of the shaft lightly contacts the roller holder (roller holder advance angle "0").
6. Adjust the stopper position so that the gap between the CSD lever and the stopper is 0.5±2 mm.
7. After adjustment, tighten the M-CSD screw to the specified torque (T).

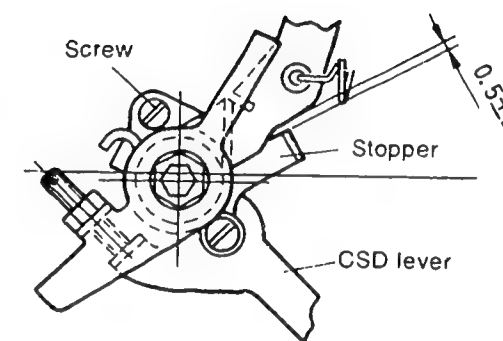

1. Setting	Pump speed (rpm)	Settings	Charge air press(mmHg)	Difference in delivery(cc)
1-1 Timing device travel	1,250	4.0~ 4.4 (mm)		
1-2 Supply pump pressure	1,250	4.4~ 5.0 (kg/cm ²)		
1-3 Full load delivery without charge air pressure	1,250	38.5~39.5 (cc/1,000st)		3.0
Full load delivery with charge air pressure		(cc/1,000st)		
1-4 Idle speed regulation	325	5.2~ 9.2 (cc/1,000st)		2.0
1-5 Start	100	Above 42 (cc/1,000st)		
1-6 Full-load speed regulation	2,400	13.1~17.1 (cc/1,000st)		
1-7				
1-8				

2. Test Specifications

2-1 Timing device	N = rpm	1,250	2,125	
	mm	3.9~ 4.5	8.5~ 9.7	
2-2 Supply pump	N = rpm	500	1,250	
	kg/cm ²	2.1~ 2.7	4.4~ 5.0	
			2,125	
			6.9~ 7.5	
2-3 Overflow delivery	N = rpm	1,250		
	cc/10s	52.0~95.0		
2-4 Fuel injection quantities				
Speed control lever position	Pump speed (rpm)	Fuel delivery (cc/1,000st)	Charge air press(mmHg)	Difference in delivery(cc)
Full speed position	1,250	38.0~40.0		
	500	32.6~36.6		
	2,125	34.1~39.1		
	2,400	12.1~18.1		
	2,500	Below 10		
Switch OFF	325	0		
Idling position	325	5.2~ 9.2		
	Below 470	0		
2-5 Solenoid	Max.cut-in voltage : 8 V			
	Test voltage : 12~14 V			

3. Dimensions

K	3.2~3.4	mm
KF	5.7~5.9	mm
MS	1.7~1.9	mm
BCS	-	mm

Control lever angle

α	29.0~37.0	deg
A	8.1~15.2	mm
β	45.0~55.0	deg
B	12.8~16.8	mm
Y	-	deg
C	-	mm

DIESEL KIKI

DIESEL KIKI CO., LTD.

Service Department

3-6-7 SHIBUYA, SHIBUYA-KU, TOKYO 150, JAPAN

Tel. (03) 400-1551 · Fax (03) 499-4115

2) FICD screw adjustment

1. Move the CSD lever so that it contacts the stopper.
2. Insert a block gauge (thickness gauge) of 9.1 ± 1 mm thickness between the control lever and idling stopper bolt.
(to position the control lever 10° from the idling position).
3. Adjust the FICD screw so that the control lever and the FICD screw are in contact.

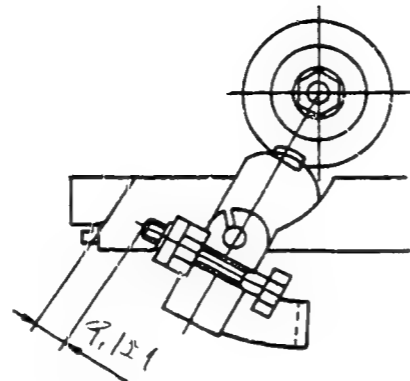

INJ. PUMP CALIBRATION DATA

Distributor-type

BOSCH No. 9 460 610 214 1/3
 DKKC No. 104748 - 0222
 Date : 28, Oct. 1988
 Company : MAZDA
 No. R230 13 800B

E - 1

104748 - 0222 2/3

TEST OIL:
 ISO 4113 or
 SAE J967d
 ENGINE MODEL : R2

Injection pump No.: 104648--0222 [NP--VE4/8F2125RNP319]

Pump rotation : clockwise-viewed from drive side

For Test Condition see
 Microfiche No. WP-210 (N-16)

Pre-stroke : — mm

1. Setting	Pump speed (rpm)	Settings	Charge air press (mmHg)	Difference in delivery (cc)
1-1 Timing device travel	1,500	4.5 ~ 4.9 (mm)		
1-2 Supply pump pressure	1,500	5.6 ~ 6.2 (kg/cm ²)		
1-3 Full load delivery without charge air pressure	1,500	37.0 ~ 38.0 (cc/1,000st)		2.0
Full load delivery with charge air pressure		(cc/1,000st)		
1-4 Idle speed regulation	350	6.0 ~ 10.0 (cc/1,000st)		2.0
1-5 Start	100	Above 42 (cc/1,000st)		
1-6 Full-load speed regulation	2,400	11.1 ~ 15.1 (cc/1,000st)		
1-7				
1-8				

2. Test Specifications

2-1 Timing device	N = rpm mm	1,250 2.9 ~ 4.1	1,500 4.4 ~ 5.0	2,125 7.0 ~ 8.2	
2-2 Supply pump	N = rpm kg/cm ²	500 2.7 ~ 3.3	1,500 5.6 ~ 6.2	2,125 7.3 ~ 7.9	
2-3 Overflow delivery	N = rpm cc/10s	1,500 55.0 ~ 98.3			
2-4 Fuel injection quantities	Speed control lever position	Pump speed (rpm)	Fuel delivery (cc/1,000st)	Charge air press (mmHg)	Difference in delivery (cc)
Full speed position		1,500	36.5 ~ 38.5		
		500	29.5 ~ 33.5		
		2,125	30.8 ~ 34.8		
		2,400	10.1 ~ 16.1		
		2,550	Below 4.0		
Switch OFF	350	0			
Idling position	350	6.0 ~ 10.0			
	455	Below 4.0			
2-5 Solenoid	Max. cut-in voltage: 8 V Test voltage: 12 ~ 14 V				

3. Dimensions

K	3.2 ~ 3.4	mm
KF	5.7 ~ 5.9	mm
MS	1.4 ~ 1.6	mm
BCS	—	mm
Control lever angle		
α	31.0 ~ 39.0	deg
A	2.5 ~ 7.7	mm
β	40.0 ~ 50.0	deg
B	12.5 ~ 15.8	mm
γ	—	deg
C	—	mm

■ M - CSD Assembly and Adjustment

1) Fixing the M-CSD stopper

- Fix the M-CSD assembly temporarily to the pump housing.
- Turn the drive shaft at least two turns in the direction of pump rotation.
- Turn the drive shaft slowly, and fix the drive shaft in a position where a load is applied (the point where the roller in the roller holder contacts the cam surface of the cam disc).
- Move the CSD lever to the advance side.
- Fix the CSD lever in the position where the ball pin at the tip of the shaft lightly contacts the roller holder (roller holder advance angle "0").
- Adjust the stopper position so that the gap between the CSD lever and the stopper is 0.5 + 2 mm. (Dimension "a").
- After adjustment, tighten the M-CSD screw to the specified torque.

$$T = 0.6 - 0.9 \text{ kg} \cdot \text{m}.$$

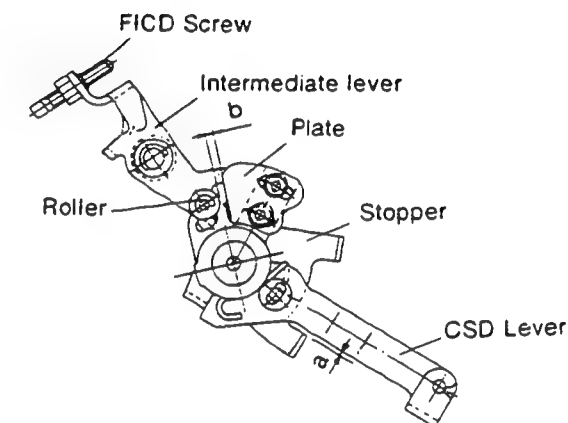

2) Fixing the CSD lever plate

1. Fix the CSD lever in a position where the gap "a" between the CSD lever and stopper is 0 mm.
2. Adjust the plate position so that the gap "b" between the intermediate lever roller and CSD lever plate is 4 mm.

After adjustment, fix the plate in this position with two screws.

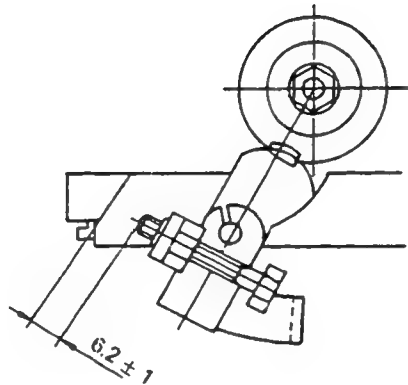

3) FICD screw adjustment

1. Move the CSD lever so that it contacts the stopper.
2. Insert a block gauge (thickness gauge) of $6.2 + 1$ mm thickness between the control lever and idling stopper bolt.
(Position 7° from idle).
3. Adjust using the FICD screw so that the control lever and FICD screw are in contact.

INJ. PUMP CALIBRATION DATA

1/5

E - 3

104748 - 0242 2/5

TEST OIL:
ISO 4113 or
SAE J967d

Distributor-type

ENGINE MODEL : RF

Injection pump No: 104648-0242 [NP-VE4/8F2325LNP351]

BOSCH No. 9 460 610 230
DKKC No. 104748 - 0242
Date : 28. Oct. 1988
Company : MAZDA
No. RF39 13 800B

For Test Condition see
Microfiche No.WP-210(N16)

Pump rotation : Counter clockwise-viewed from drive side
Pre-stroke : - mm

1. Setting	Pump speed (rpm)	Settings	Charge air press(mmHg)	Difference in delivery(cc)
1-1 Timing device travel	1,375	4.0~ 4.4 (mm)		
1-2 Supply pump pressure	1,375	4.4~ 5.0 (kg/cm ²)		
1-3 Full load delivery without charge air pressure	1,375	35.4~36.4 (cc/1,000st)		2.5
Full load delivery with charge air pressure		(cc/1,000st)		
1-4 Idle speed regulation	410	7.0~ 9.0 (cc/1,000st)		2.0
1-5 Start	100	Above 42.0 (cc/1,000st)		
1-6 Full-load speed regulation	2,600	10.8~14.8 (cc/1,000st)		
1-7 Load timer adjustment	1,375	3.6±0.2 (mm)		
1-8				

2. Test Specifications

2-1 Timing device	N = rpm	1,375	1,800	2,325	
	mm	3.9~ 4.5	6.1~ 7.3	7.2~ 8.4	
2-2 Supply pump	N = rpm	600	1,375	2,325	
	kg/cm ²	2.2~ 2.8	4.4~ 5.0	6.9~ 7.5	
2-3 Overflow delivery	N = rpm	1,375			
	cc/10s	46.3~90.3			
2-4 Fuel deliveries	Speed control lever	Pump speed (rpm)	Fuel delivery (cc/1,000st)	Charge air press(mmHg)	Difference in delivery
	End stop	2,700	Below 6.0		
		2,600	9.8~15.8		
		2,325	30.2~34.2		
		1,375	34.9~36.9		
		600	29.0~33.0		
	Switch OFF	410	0		
	Idle stop	410	6.0~10.0		
2-5 Solenoid	Max.cut-in voltage : 8 V				
	Test voltage : 12~14 V				

3. Dimensions

K	3.2 ~3.4	mm
KF	5.7 ~5.9	mm
MS	1.4 ~1.6	mm
BCS	—	mm

Control lever angle

α	16.0~24.0	deg
A	5.7~10.9	mm
β	40.0~50.0	deg
B	12.7~16.0	mm
Y	—	deg
C	—	mm

LOAD TIMER ADJUSTMENT

1) Adjustment

① Fix the control lever in the position satisfying the following conditions.

Boost Pressure :	—	mmHg
Pump Speed :	1375	rpm
Fuel Injection :	28.2±1	cc/1000st
Quantity		

② With the control lever positioned as described in ① above, adjust the governor sleeve so that Timer Stroke conforms to the specified values (page 1/5).

2) Confirmation of Timer Characteristics

Fix the control lever in the position satisfying the following conditions, and confirm the Timer Stroke.

Control lever position			Specified Values	
Pump speed (rpm)	Fuel Injection Quantity(cc/1000st)	Boost pressure (mmHg)	Timer stroke (mm)	Timer stroke reduction value (mm)
1,375	28.2±1.5	—	3.6±0.3	—
1,375	16.1±1.5	—	2.4±0.7	—



DIESEL KIKI CO., LTD.
Service Department

3-6-7 SHIBUYA, SHIBUYA-KU, TOKYO 150, JAPAN
Tel (03) 400-1551 Fax (03) 499-4115

Side Link Lever Adjustment

1) Side link lever adjustment

1. Fix the control lever in the idling position.
2. Check that side link levers (1) and (2) contact the stoppers. (Portion A)

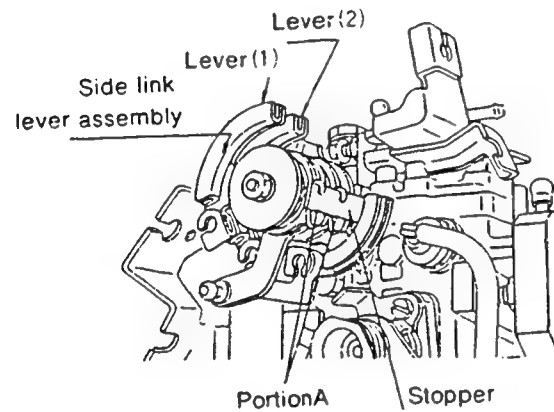

3. If control lever (4) and lever (3) are not connected by rod (5), connect them.
4. After connecting rod (5), adjust the length of rod (5) so that the gap at the hook of lever (3) and levers (1) and (2) is 0.5 ± 1.0 mm.

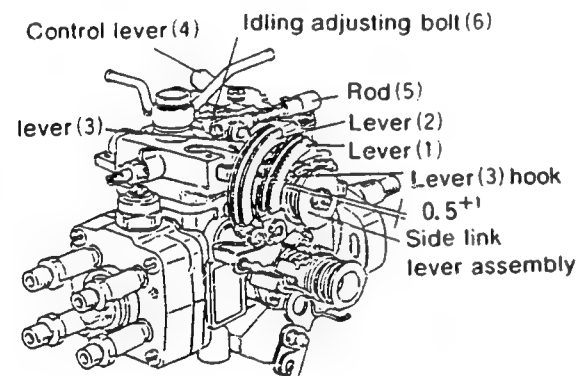

2) M-CSD adjustment

1. Loosen M-CSD lock screw (7).
2. Turn the drive shaft two or three turns and set the measuring device at 0.
3. Move the CSD lever gently in the direction of the arrow (advance direction).
4. Fix the CSD lever in a position where the CSD lever shaft ball pin contacts the roller holder. (Move gently, and hold the CSD lever in the position where the resistance changes.)
5. Check that the measuring device is at the 0 point.
6. Adjust the position of the stopper so that the gap between CSD lever (8) and stopper (9) is 0.5 ± 2 mm, and then fix in position using screw (7).
7. Turn the drive shaft two or three turns, check the position of the measuring device 0 point, and then recheck the gap between CSD lever (8) and stopper (9).

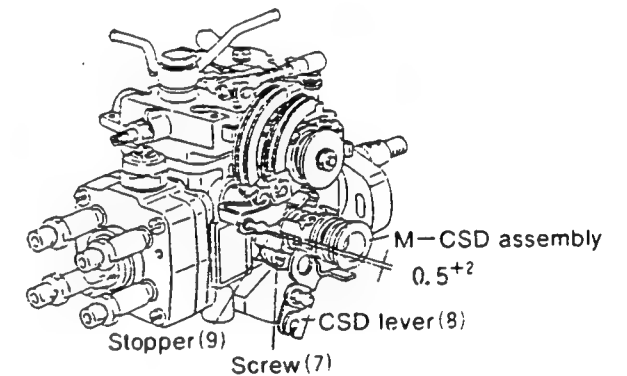
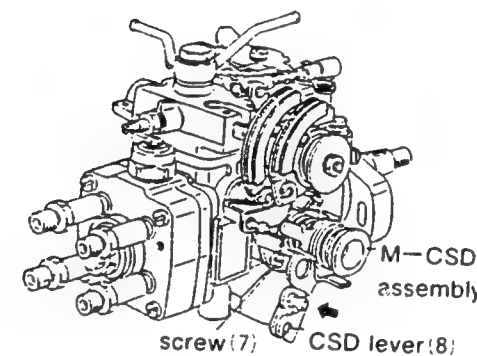

3) Fixing the CSD lever and side link lever connecting rod

1. Connect the side link lever assembly and CSD lever using rod (10).
2. Move the CSD lever through its full stroke (in the direction the arrow).
3. Adjust the length of rod (10) so that the gap between control lever (4) and idling adjusting bolt (6) is 8.5 mm, and then fix in this position. (Target engine speed: 1900rpm)

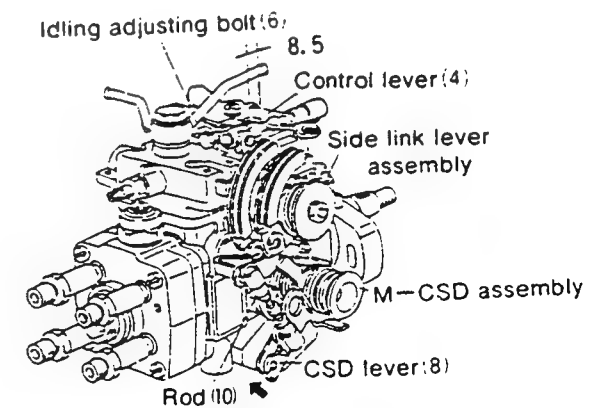

4) Fixing the engine installation bracket

1. Fix the bracket temporarily to the pump.
2. Move the bracket in the direction of the arrow until the clearance is 0.
3. Fix the bracket in position using the bolts.

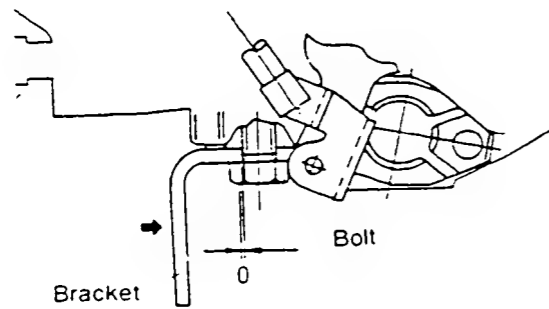

DASH POT ADJUSTMENT

- 1 Insert a block gauge (thickness gauge) of thickness 8.5 in the gap between the control lever and the idling stopper bolt. (control lever angle : 13°)
- 2 With the control lever positioned as described in 1 above, adjust the Dashpot adjusting screw so that the Dashpot adjusting screw and the push rod are in contact. Fix using the nut.

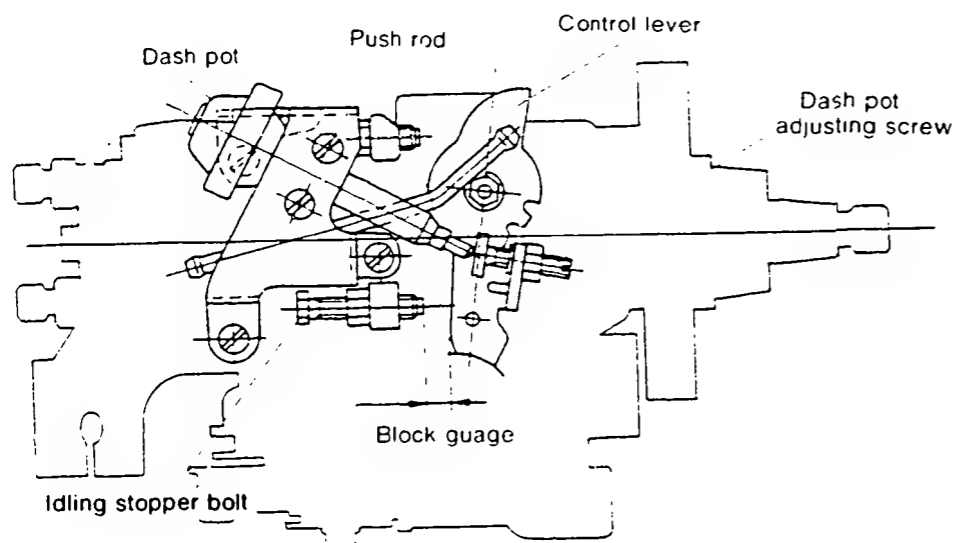

INJ. PUMP CALIBRATION DATA

Distributor-type

TEST OIL:
ISO 4113 or
SAE J967d

ENGINE MODEL : 4EC1

BOSCH No. 9 460 610 330 1/5
DKKC No. 104748 - 1780
Date : 28. Oct. 1988
Company : ISUZU
No. 894317 8480

E - 6

104748 - 1780 2/5

Injection pump No.: 104648-1780 [NP-VE4/8F2600RNP684]

Pump rotation : clockwise-viewed from drive side

For Test Condition see
Microfiche No. WP-210 (N-16)

Pre-stroke : — mm

1. Setting		Pump speed (rpm)	Settings	Charge air press (mmHg)	Difference in delivery (cc)
1-1	Timing device travel	1,250	T = 2.7 - 3.1 (mm)		
1-2	Supply pump pressure	1,250	3.5 - 3.9 (kg/cm ²)		
1-3	Full load delivery without charge air pressure	1,500	32.8 - 33.8 (cc/1,000st)		2.5
	Full load delivery with charge air pressure		(cc/1,000st)		
1-4	Idle speed regulation	375	7.6 - 11.6 (cc/1,000st)		2.0
1-5	Start	100	45.0 - 65.0 (cc/1,000st)		
1-6	Full-load speed regulation	2,850	13.0 - 19.0 (cc/1,000st)		3.5
1-7	Load - timer adjustment	1,250	T - 0.8 ± 0.2 (mm)		
1-8					

2. Test Specifications

2-1	Timing device	N = rpm mm	1,250 2.6 - 3.2	2,000 5.5 - 6.7	2,300 7.0 - 7.8
2-2	Supply pump	N = rpm kg/cm ²	500 1.6 - 2.2	1,250 3.5 - 3.9	2,000 5.2 - 5.8
2-3	Overflow delivery	N = rpm cc/10s	1,250 40.0 - 83.3		

2-4 Fuel injection quantities

Speed control lever position	Pump speed (rpm)	Fuel delivery (cc/1,000st)	Charge air press (mmHg)	Difference in delivery (cc)
Full speed position	1,500	32.3 - 34.3		
	600	30.1 - 34.1		
	1,000	29.9 - 33.9		
	2,400	27.6 - 31.6		
	2,600	26.2 - 30.4		
	2,700	23.5 - 30.5		
	2,850	12.5 - 19.5		
	2,975	Below 6.0		
Switch OFF	375	0		
Idling position	375	7.6 - 11.6		
	500	Below 5.0		

3. Dimensions

K	3.2 - 3.4	mm
KF	5.7 - 5.9	mm
MS	1.3 - 1.5	mm
BCS	—	mm

Control lever angle

α	16.0 - 24.0	deg
A	11.2 - 13.8	mm
β	40.0 - 50.0	deg
B	12.9 - 16.1	mm
γ	—	deg
C	—	mm

LOAD TIMER ADJUSTMENT

1) Adjustment

i Fix the control lever in the position satisfying the following conditions.

Boost Pressure : — mmHg

Pump Speed : 1,250 rpm

Fuel Injection Quantity : 18.1 ± 0.5 cc/1000st

2 With the control lever positioned as described in i above, adjust the governor sleeve so that the Timer Stroke conforms to the specified values (Item 1/5).

Control lever position			Specified Values	
Pump speed (rpm)	Fuel Injection Quantity (cc/1000st)	Boost pressure (mmHg)	Timer stroke (mm)	Timer stroke reduction value (mm)
1,250	18.1 ± 1	—	—	0.8 ± 0.4
1,250	7 ± 1.5	—	—	2.2 ± 0.6



DIESEL KIKI CO. LTD.
Service Department

3-6-7 SHIBUYA, SHIBUYA-KU TOKYO 150, JAPAN
Tel (03) 400-1551 · Fax (03) 499-4115

■ V - FICD Adjustment (adjust with W - CSD released)

1) V - FICD installation position adjustment

1. Fix the control lever in the idling position.
2. Adjust the position of the V - FICD bracket so that the gap "S" between the actuator shaft and the pin press-fitted to the control lever is 1 ± 1 mm.

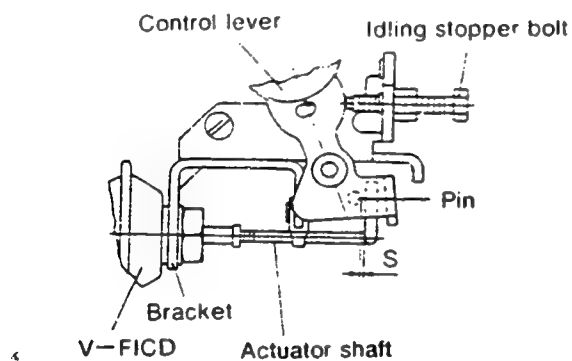

2) V - FICD Stroke Adjustment

1. Hold the control lever in the idling position.
2. Apply a negative pressure of 350 mmHg to the inside of the actuator.
3. Adjust using the stroke adjusting screw so that the clearance "l" between the control lever and the idling stopper bolt is 1.6 ± 0.1 mm.
4. After adjusting, tighten securely using the locknut.
Tightening torque: 0.12 - 0.15 kg-m.

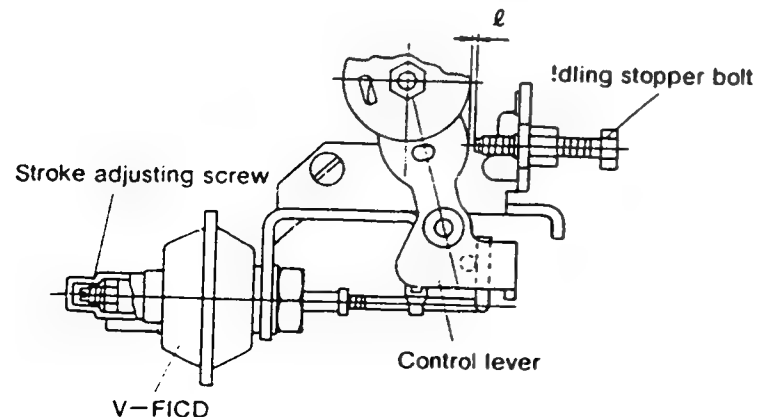

■ W - CSD Adjustment

1) Timer Stroke Adjustment (adjust to the thick line)

1. Calculate the timer stroke from Fig. 2 according to the atmospheric temperature at the time of adjustment.

2) Intermediate Lever Position Adjustment

1. Insert a block gauge (thickness gauge) of 1.2 ± 0.05 mm thickness between the control lever and the idling stopper bolt.
2. Align the intermediate lever with the aligning mark.
3. Adjust the intermediate lever set screw so that the control lever and the intermediate lever set screw are in contact, and then fix in position using the locknut.

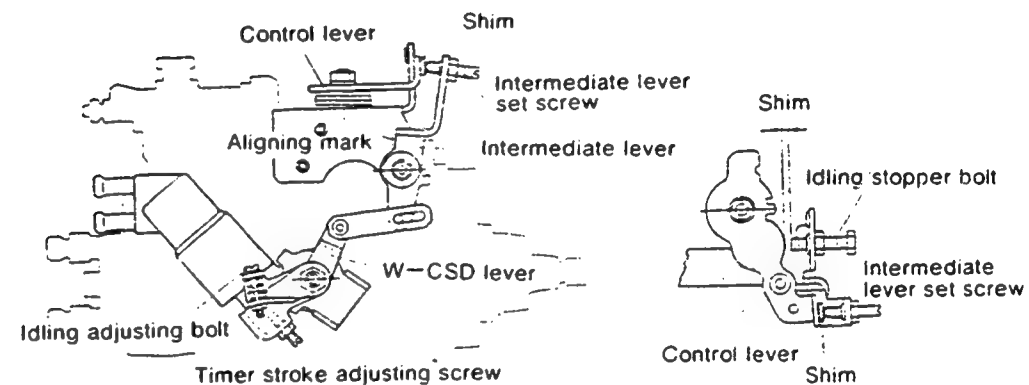

Fig. 1

3) CSD Lever Adjustment (adjust to the thick line)

1. Calculate the block gauge dimension $l \pm 0.05$ mm from Fig. 2 according to the atmospheric temperature at the time of adjustment.
2. Insert the block gauge (thickness gauge) between the control lever and the idling stopper bolt.
3. Using the idling bolt, adjust so that the CSD lever roller and the intermediate lever are in contact.

Formula for calculating Fig. 2

Formula for calculating timer stroke:

$$T = -0.0235t + 0.585$$

Formula for calculating control lever and idling stopper bolt gap:

When $-20 \leq t \leq 20^\circ\text{C}$ $l = -0.02075 t + 1.585$

When $20 \leq t \leq 50^\circ\text{C}$ $l = -0.039 t + 1.95$

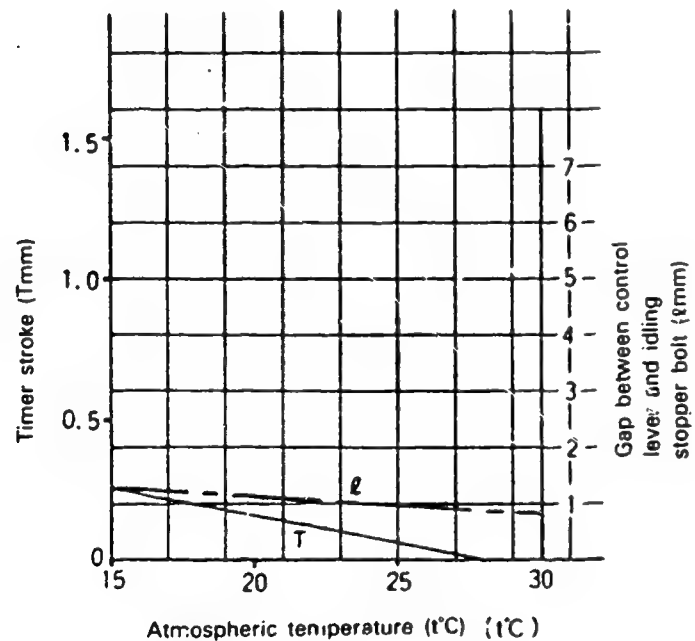

Fig. 2

INJ. PUMP CALIBRATION DATA

Distributor-type

MOTOR : CD17

TEST OIL:
I S O 4113 or
S A E J967d

Injection pump No: 104648 - 2451 (NP-VE4/8F2500LNP427)

Pump rotation : Counter clockwise-viewed from drive side

Pre-stroke : - mm

BOSCH No. 9 460 610 257
DKKC No. 104748 - 2451
Date : 28. Oct. 2988
Company : NISSAN
No. 16700 62M00

For Test Condition see
Microfiche No.WP-210(N16)

1. Setting	Pump speed (rpm)	Settings	Charge air press(mmHg)	Difference in delivery(cc)
1-1 Timing device travel	1,200	1.5~ 2.1 (mm)		
1-2 Supply pump pressure	1,200	3.1~ 3.7 (kg/cm ²)		
1-3 Full load delivery without charge air pressure	1,000	27.1~28.1 (cc/1,000st)		2.5
Full load delivery with charge air pressure		(cc/1,000st)		
1-4 Idle speed regulation	360	3.7~ 6.7 (cc/1,000st)		
1-5 Start	100	50.3~60.3 (cc/1,000st)		
1-6 Full-load speed regulation	2,700	11.8~17.8 (cc/1,000st)		
1-7				
1-8				

2. Test Specifications

2-1 Timing device	N = rpm	1,200	1,800	2,500		
	mm	1.4~ 2.2	3.5~ 4.7	6.9~ 7.8		
2-2 Supply pump	N = rpm	1,200	1,800	2,500		
	kg/cm ²	3.0~ 3.8	4.4~ 5.2	6.1~ 6.9		
2-3 Overflow delivery	N = rpm	1,200				
	cc/10s	36.0~80.0				
2-4 Fuel injection quantities						
Speed control lever position	Pump speed (rpm)	Fuel delivery (cc/1,000st)	Charge air press(mmHg)	Difference in delivery(cc)		
Full speed position	1,000	26.6~28.6				
	600	24.8~28.8				
	2,500	24.3~28.3				
	2,700	11.3~18.3				
	2,900	Below 6.0				
Switch OFF	360	0				
Idling position	360	3.2~7.2 Below 3.0		2.5		
Partial load	700	10.8~19.8				
2-5 Solenoid	Max.cut-in voltage : 8 V Test voltage : 12~14 V					

3. Dimensions

K	3.2~3.4	mm
KF	5.7~5.9	mm
MS	1.5~1.7	mm
BCS	-	mm

Control lever angle

α	1.0~-1.0	deg
YA	15.4~18.1	mm
β	39.0~49.0	deg
B	11.0~16.0	mm
Y	13.5~14.5	deg
C	8.6~ 9.2	mm

Control Lever Angle Measurement Position

(1) Measure the control lever angles (α, β, γ) at hole A.

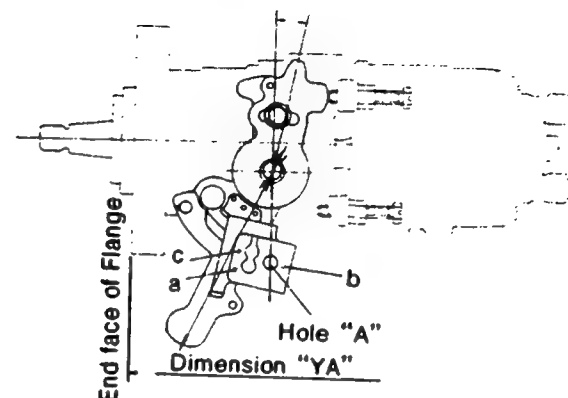

Starting Injection Quantity Adjustment

Adjust the starting injection quantity (item 1/5) using the adjusting bolt (as shown in the figure at right).

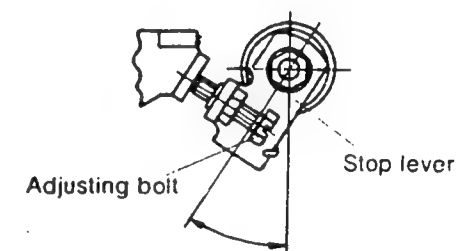

■ POTENTIOMETER ADJUSTMENT

Under the following conditions, after potentiometer installation position so that the out-put voltage equale the specified value.

Adjustment Conditions			Specified Value	Remarks
Control lever position	Pump speed (rpm)	Fuel Injection Quantity(cc/1000st)	Adjustment Value Out-put voltage (V)	
(Approx 14°)	700	measure	measure	Adjusting point
Idel	---	---	---	Check point
Full speed	---	---	---	Check point

(In-put Voltage.10V)

∴ A control lever position of approximately 14° means that a block gauge of 8.9 mm thickness is inserted between the control lever and the idling stopper bolt.

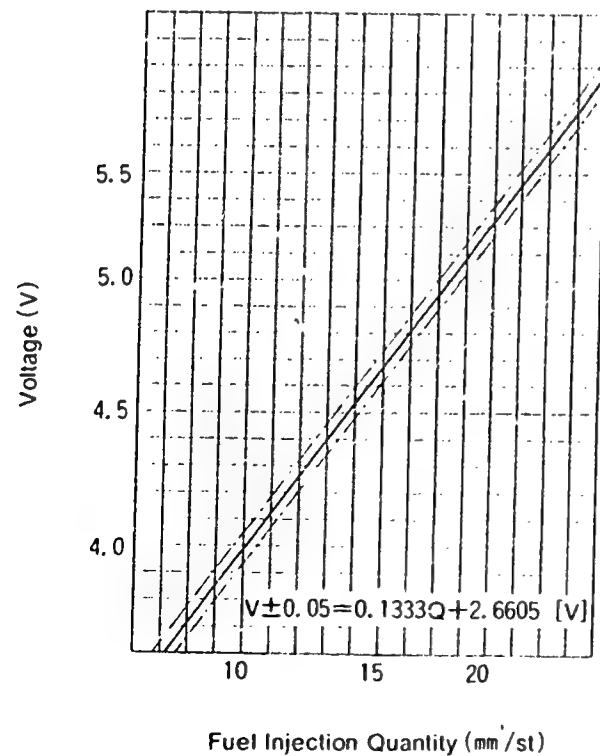

■ W-CSD Adjustment

1) Timer stroke adjustment

1. Calculate the timer stroke from Fig. 2 according to the atmospheric temperature at the time of adjustment.
2. Adjust using timer stroke adjusting screw so that the timer stroke is as calculated in Step 1.

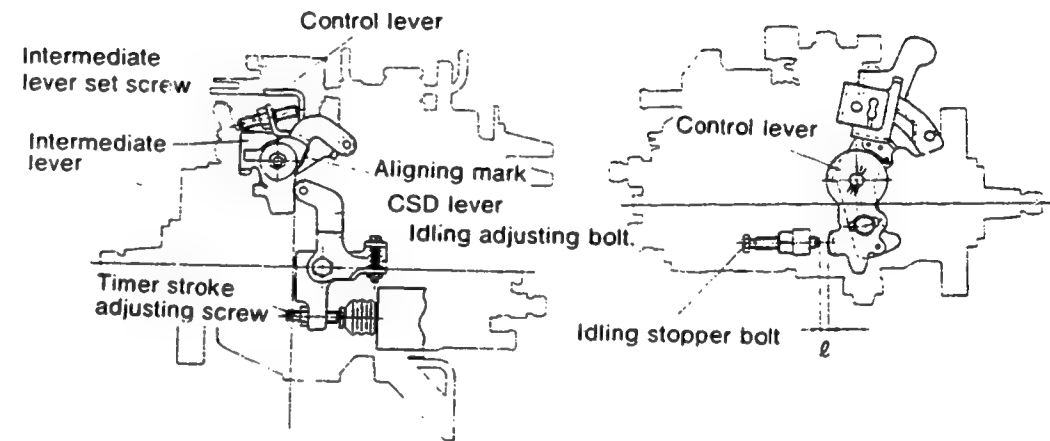

Fig. 1

2) Intermediate lever position adjustment

1. Insert a block gauge (thickness gauge) of 4.1 ± 0.05 mm thickness between the control lever and the idling stopper bolt.
2. Align the intermediate lever with the aligning mark.
3. Adjust the intermadiate lever set screw so that the control lever and intermediate lever set screw are in contact, and then fix in position using the locknut.

3) CSD lever adjustment

1. Calculate the block gauge dimension $\ell \pm 0.05\text{mm}$ from Fig. 2 according to the atmospheric temperature at the time of adjustment.
2. Insert the block gauge (thickness gauge) between the control lever and the idling stopper bolt
3. Using the idling bolt, adjust so that the CSD lever roller and intermediate lever are in contact.

Notes :

1. The temperature of the wax must be below 30°C when adjusting.
2. When inserting a block gauge (thickness gauge) between the control lever (beacket) and the idling stopper bolt, use the idling adjusting bolt to separate the CSD lever and intermediate lever so that no excessive force is exerted on them.

Formula for calculating Fig. 2

Formula for calculating timer stroke:

$$\text{When } 10 \leq t \leq 20 \quad T = -0.027t + 1.09$$

$$\text{When } 20 < t \leq 40 \quad T = -0.0275t + 1.1$$

Formula for calculating control lever and idling stopper bolt gap:

$$\text{When } t \leq 10 \quad \ell = 4.6$$

$$\text{When } 10 < t \leq 20 \quad \ell = -0.17t + 6.3$$

$$\text{When } 20 < t \leq 28.5 \quad \ell = -0.235t + 7.6$$

$$\text{When } 28.5 < t \leq 36 \quad \ell = -0.12t + 4.32$$

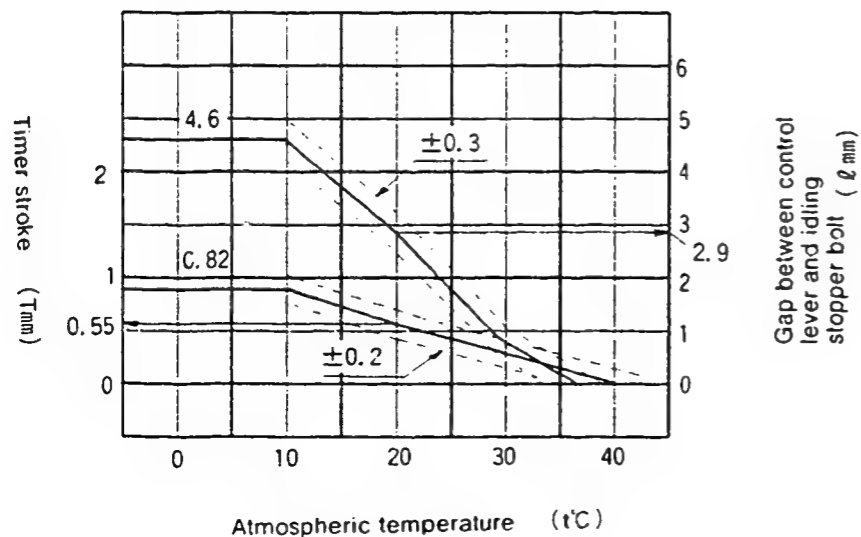

Fig. 2

INJ. PUMP CALIBRATION DATA

Distributor-type

TEST OIL:
ISO 4113 or
SAE J967d

ENGINE MODEL : LD20

Injection pump No.: 104649-2240 [NP-VE4/9F2300RNP454]

BOSCH No. 9 460 610 196 1/4
DKKC No. 104749 - 2240
Date : 28, Oct. 1988
Company : NISSAN
No. 16700 14C00

E - 12

104749 - 2240 2/4

Pump rotation : clockwise-viewed from drive side

For Test Condition see
Microfiche No. WP-210 (N-16)

Pre-stroke : — mm

1. Setting		Pump speed (rpm)	Settings	Charge air press (mmHg)	Difference in delivery (cc)
1-1	Timing device travel	900	T = 1.3 - 1.7 (mm)		2.5
1-2	Supply pump pressure	900	3.2 - 3.8 (kg/cm ²)		
1-3	Full load delivery without charge air pressure	900	32.5 - 33.5 (cc/1,000st)		
	Full load delivery with charge air pressure		(cc/1,000st)		
1-4	Idle speed regulation	350	4.7 - 7.7 (cc/1,000st)		
1-5	Start	100	40 - 50 (cc/1,000st)		
1-6	Full-load speed regulation	2,500	10.6 - 16.6 (cc/1,000st)		
1-7	Load - timer adjustment	900	T - 0.65 ± 0.2 (mm)		
1-8					

2. Test Specifications

2-1	Timing device	N = rpm mm	900 1.2 - 1.8	1,800 5.5 - 6.7	2,300 7.7 - 8.9
2-2	Supply pump	N = rpm kg/cm ²	900 3.1 - 3.9	1,800 5.1 - 5.9	2,300 6.2 - 7.0
2-3	Overflow delivery	N = rpm cc/10s	900 35.0 - 79.0		
2-4	Fuel injection quantities				
	Speed control lever position	Pump speed (rpm)	Fuel delivery (cc/1,000st)	Charge air press(mmHg)	Difference in delivery (cc)
	Full speed position	900	32.0 - 34.0		2.5
		600	31.2 - 35.2		
		2,300	28.9 - 32.8		
		2,500	10.1 - 17.1		
		2,600	Below 6.0		
	Switch OFF	350	0		
	Idling position	350	4.2 - 6.2		2.5
		500	Below 4.5		
	Partial load	900	4.1 - 14.1		
2-5	Solenoid	Max. cut-in voltage: 8 V Test voltage: 12 - 14 V			

3. Dimensions

K	3.2 - 3.4	mm
KF	5.7 - 5.9	mm
MS	1.1 - 1.3	mm
BCS	—	mm
Control lever angle		
a	21.0 - 29.0	deg
A	4.3 - 9.6	mm
β	36.0 - 46.0	deg
B	10.9 - 14.6	mm
γ	10.5 - 11.5	deg
C	6.9 - 7.5	mm

LOAD TIMER ADJUSTMENT

1) Adjustment

- Fix the control lever in the position satisfying the following conditions.

Boost Pressure : — mmHg
Pump Speed : 900 rpm
Fuel Injection : 17 ± 1 cc/1000st

- With the control lever positioned as described in 1) above, adjust the governor sleeve so that the Timer Stroke conforms to the specified values (page 1/4).

Starting Injection Quantity Adjustment

Adjust the starting injection quantity (item 1/5) using the adjusting bolt (as shown in the figure at right)

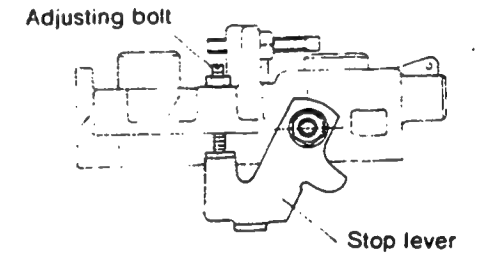

■ M — CSD Adjustment

- 1) Fix the intermediate lever adjustment screw in position (adjust with the M — CSD released).
 1. Hold the control lever (3) in the idling position.
 2. Insert a 1.5 mm block gauge (thickness gauge) between the intermediate lever (4) and the intermediate lever bracket (11), and then fix the intermediate lever (4) in a position where the adjusting screw (1) is horizontal.
 3. Adjust using the adjusting screw (1) so that the gap between the control lever (3) and the adjusting screw (1) is 1 mm, and then fix the screw using the nut.

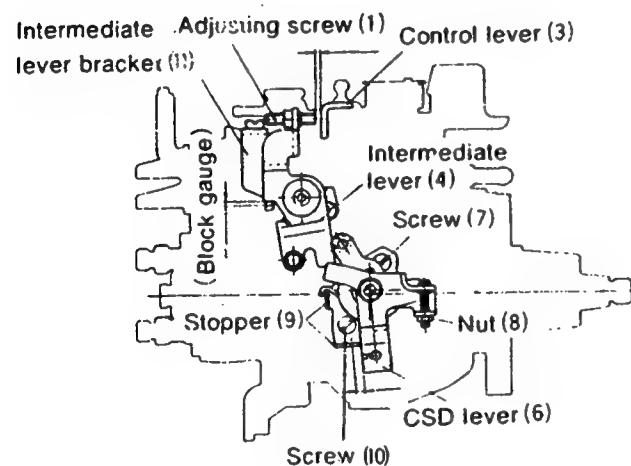

2) Fixing the M — CSD Stopper (9)

1. Turn the drive shaft slowly and fix the drive shaft in a position where a load is applied (the point where the roller in the roller holder contacts the cam surface of the cam disc).
2. Move the CSD lever (6) to the advance side.
3. Fix the CSD lever in the position where the ball pin at the tip of the shaft lightly contacts the roller holder (roller holder advance angle "0").
4. Adjust the stopper position so that the gap between the CSD lever (6) and the stopper (9) is 4.5 mm, and then fix the stopper using the screw (10).
5. Move the M — CSD lever (6) until it contacts the stopper (9), and check that the timer stroke at this point is 1.23 ± 0.2 mm.

3) Screw (7) Adjustment

1. Hold the control lever in the idling position.
2. Adjust using the idling adjusting screw (7) so that the gap between the control lever (3) and the intermediate lever set screw (1) is 1 mm, and then fix the screw (7) using the nut (8).
3. Operate the CSD lever (6) (move the CSD lever until it contacts the stopper (9)).
4. Check that the gap between the control lever (3) and the idling stopper bolt is 7.2 ± 0.5 mm.

INJ. PUMP CALIBRATION DATA

Distributor-type

TEST OIL:
ISO 4113 or
SAE J967d

ENGINE MODEL : LD20

Injection pump No.: 104649-2190 [NP-VE4/9F2500RNP359]

Pump rotation : clockwise-viewed from drive side

Pre-stroke : — mm

BOSCH No. 9 460 610 250 1/4
DKKC No. 104749 - 2260
Date : 28, Oct. 1988
Company : NISSAN
No. 16700 D4600

For Test Condition see
Microfiche No. WP-210 (N-16)

E - 14

104749 - 2260 2/4

1. Setting	Pump speed (rpm)	Settings	Charge air press (mmHg)	Difference in delivery (cc)
1-1 Timing device travel	900	T = 1.3 ~ 1.7 (mm)		2.5
1-2 Supply pump pressure	900	3.2 ~ 3.8 (kg/cm ²)		
1-3 Full load delivery without charge air pressure	900	32.5 ~ 33.5 (cc/1,000st)		
		(cc/1,000st)		
1-4 Idle speed regulation	350	4.7 ~ 7.7 (cc/1,000st)		
1-5 Start	100	40.0 ~ 50.0 (cc/1,000st)		
1-6 Full-load speed regulation	2,700	10.9 ~ 16.9 (cc/1,000st)		
1-7 Load - timer adjustment	900	T = 0.65 ± 0.2 (mm)		
1-8				

2. Test Specifications

2-1 Timing device	N = rpm mm	900 1.2 ~ 1.8	1,800 5.5 ~ 6.7	2,300 7.7 ~ 8.9
2-2 Supply pump	N = rpm kg/cm ²	900 3.1 ~ 3.9	1,800 5.1 ~ 5.9	2,500 6.8 ~ 7.6
2-3 Overflow delivery	N = rpm cc/10s	900 35.0 ~ 79.0		
2-4 Fuel injection quantities				
Speed control lever position	Pump speed (rpm)	Fuel delivery (cc/1,000st)	Charge air press (mmHg)	Difference in delivery (cc)
Full speed position	2,800	Below 6.0		
	2,700	10.4 ~ 17.4		
	2,300	30.6 ~ 34.6		
	900	32.0 ~ 34.0		
	600	31.2 ~ 35.2		
Switch OFF	350	0		
Idling position	350	4.2 ~ 8.2		2.2
	500	Below 4.5		
Partial load	900	4.1 ~ 14.1		
2-5 Solenoid	Max. cut-in voltage: 8 V Test voltage: 12 ~ 14 V			

3. Dimensions

K	3.2 ~ 3.4	mm
KF	5.7 ~ 5.9	mm
MS	1.1 ~ 1.3	mm
BCS	—	mm

Control lever angle

α	21.0 ~ 29.0	deg
A	7.6 ~ 11.7	mm
β	39.0 ~ 49.0	deg
B	11.9 ~ 15.6	mm
γ	10.5 ~ 11.5	deg
C	5.5 ~ 6.1	mm

LOAD TIMER ADJUSTMENT

1) Adjustment

① Fix the control lever in the position satisfying the following conditions.

Boost Pressure : — mmHg
Pump Speed : 900 rpm
Fuel Injection : 17.1 ± cc/1000st
Quantity

② With the control lever positioned as described in ① above, adjust the governor sleeve so that the Timer Stroke conforms to the specified values (Item 1 - 7).

W - CSD Adjustment

1) Timer Stroke Adjustment (adjust to the thick line)

1. Calculate the timer stroke from Fig. 2 according to the atmospheric temperature at the time of adjustment.

2. Adjust using the timer stroke adjusting screw so that the timer stroke is as calculated.

2) Intermediate Lever Position Adjustment

1. Insert a block gauge (thickness gauge) of 0.25 ± 0.05 mm thickness between the bracket and the idling stopper bolt.

2. Align the intermediate lever with the aligning mark.

3. Adjust the intermediate lever set screw so that the control lever and the intermediate lever set screw are in contact, and then fix in position using the locknut.

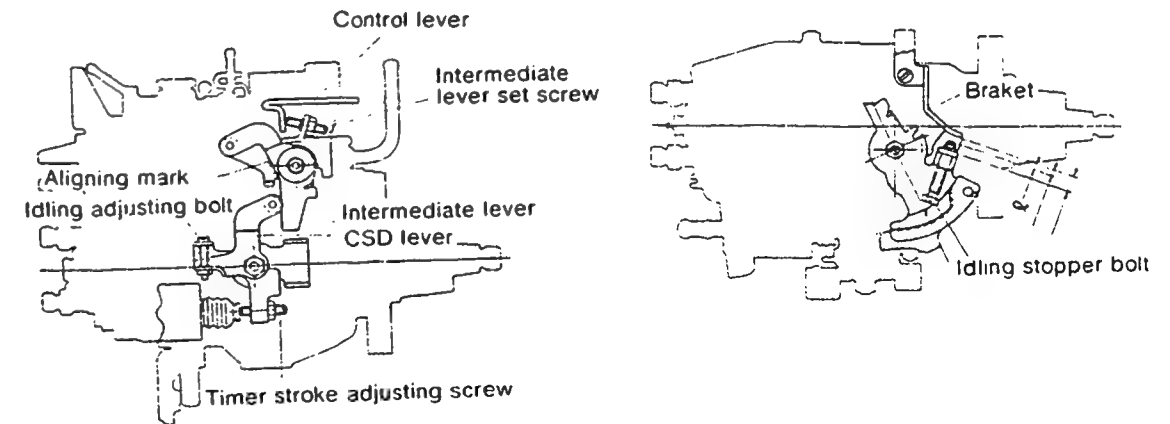

Fig. 1

Formula for calculating Fig. 2

Formula for calculating timer stroke: $T = -0.0367t + 1.424$

Formula for calculating control lever and idling stopper bolt gap: $l = -0.095l + 3.6$

Thick line: For temporary adjustment

Thin line: For final adjustment

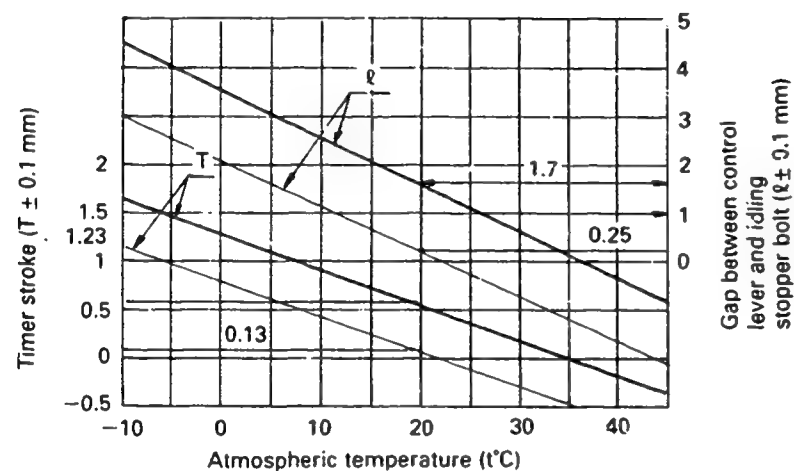

Fig. 2

3) CSD Lever Adjustment (adjust to the thick line)

1. Calculate the block gauge dimension $l \pm 0.05$ mm from Fig. 2 according to the atmospheric temperature at the time of adjustment.
2. Insert the block gauge (thickness gauge) selected in Step (1) above between the bracket and the idling stopper bolt.
3. Using the idling bolt, adjust so that the CSD lever roller and the intermediate lever are in contact.

4) Final Adjustment

After completing the adjustment, screw the timer stroke adjusting screw two turns clockwise.

(Move from the temporary adjustment chart to the final adjustment chart.)

※ This W — CSD's timer stroke operations are effective at atmospheric temperatures of 27°C or above.

Therefore, to make adjustment at normal temperatures possible, after adjusting to the substitute characteristics, tighten the timer stroke adjusting screw two turns.

■ DASH POT ADJUSTMENT

- ① Insert a block gauge (thickness gauge) of thickness 3.8 ± 0.05 mm in the gap between the idling stopper bolt and the bracket.
- ② With the control lever positioned as described in ① above, adjust the dashpot adjusting screw so that the dashpot adjusting screw and the push rod are in contact. Fix the screw using the nut.

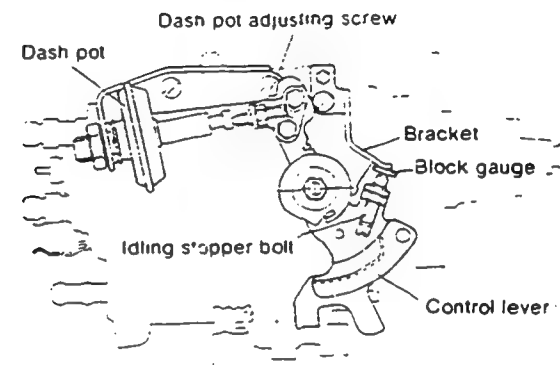

■ Starting Injection Quantity Adjustment

Adjust the starting injection quantity (item 1/5) using the adjusting bolt (as shown in the figure at right).

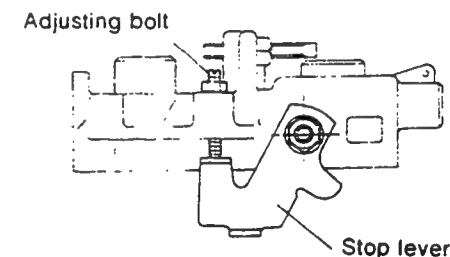

INJ. PUMP CALIBRATION DATA

1/5

F - 1

TEST OIL:
ISO 4113 or
SAE J967d

Distributor-type

ENGINE MODEL : 4D65

BOSCH No. 9 460 610 217

DKKC No. 104749 - 3030

Date : 28, Oct. 1988

Company : MITSUBISHI

No. MD077260

104749 - 3030 2/5

Injection pump No: 104649 - 3020 [NP-VE4/9F2250RNP280]

Pump rotation : clockwise-viewed from drive side

For Test Condition see
Microfiche No.WP-210(N16)

Pre-stroke : - mm

1. Setting	Pump speed (rpm)	Settings	Charge air press(mmHg)	Difference in delivery(cc)
1-1 Timing device travel	1,250	T=3.9~ 4.3 (mm)	580~600	
1-2 Supply pump pressure	1,250	4.5~ 5.1 (kg/cm ²)	580~600	
1-3 Full load delivery without charge air pressure	1,250	46.3~47.3 (cc/1,000st)	580~600	3.0
Full load delivery with charge air pressure	750	40.2~41.2 (cc/1,000st)	240~260	3.5
1-4 Idle speed regulation	400	5.0~ 8.0 (cc/1,000st)	0	2.0
1-5 Start	100	43.0~63.0 (cc/1,000st)	0	
1-6 Full-load speed regulation	2,750	3.5~ 9.5 (cc/1,000st)	0	
1-7 Load-timer adjustment	1,250	T=0.6±0.2 (mm)		
1-8				

2. Test Specifications

2-1 Timing device	N = rpm	600	1,250	2,250	
	mm	0.7~ 1.9	3.7~ 4.5	7.8~ 8.6	
2-2 Supply pump	N = rpm	600	1,250	2,250	
	kg/cm ²	2.9~ 3.5	4.5~ 5.1	6.8~ 7.4	
2-3 Overflow delivery	N = rpm	1,250			
	cc/10s	48.0~92.0			
2-4 Fuel deliveries	Speed control lever	Pump speed (rpm)	Fuel delivery (cc/1,000st)	Charge air press(mmHg)	Difference in delivery
	End stop	1,250	45.8~47.8	580~600	
		750	39.7~41.7	240~260	
		600	32.7~37.7	0	
		2,250	38.2~43.2	580~600	
		2,750	1.5~11.5	0	
		3,000	Below 3.0	0	
	Switch OFF	400	0		
	Idle stop	600	Below 2.0	0	
		400	4.5~ 8.5	0	
2-5 Solenoid	Max.cut-in voltage : 8 V				
	Test voltage : 12~14 V				

3. Dimensions

K	3.2~3.4	mm
KF	5.7~5.9	mm
MS	0.9~1.1	mm
BCS	3.5~3.7	mm

Control lever angle

α	55.0~63.0	deg
A	10.5~16.0	mm
β	38.0~44.0	deg
B	11.5~14.1	mm
γ	—	deg
C	—	mm

LOAD TIMER ADJUSTMENT

1) Adjustment

① Fix the control lever in the position satisfying the following conditions.

Boost Pressure :	—	mmHg
Pump Speed :	1250	rpm
Fuel Injection :	33.2±1	cc/1000st
Quantity		

② With the control lever positioned as described in ① above, adjust the governor sleeve so that the Timer Stroke conforms to the specified values (page 1/5)

2) Confirmation of Timer Characteristics

Fix the control lever in the position satisfying the following conditions, and confirm the Timer Stroke.

Control lever position			Specified Values	
Pump speed (rpm)	Fuel Injection Quantity(cc/1000st)	Boost pressure (mmHg)	Timer stroke (mm)	Timer stroke reduction value (mm)
1250	32.2~34.2	—	(3.5)	0.2~1.0
1250	24.2~26.2	—	(2.3~3.5)	(1.2)

■ DASH POT ADJUSTMENT

- 1 Insert a block gauge (thickness gauge) of thickness 5.2 ± 1 in the gap between the control lever and the idling stopper bolt. (control lever angle : $6^\circ \sim 10^\circ$)
- 2 With the control lever positioned as described in ① above, adjust the plate position so that the control lever plate and the dash pot push rod are in contact.

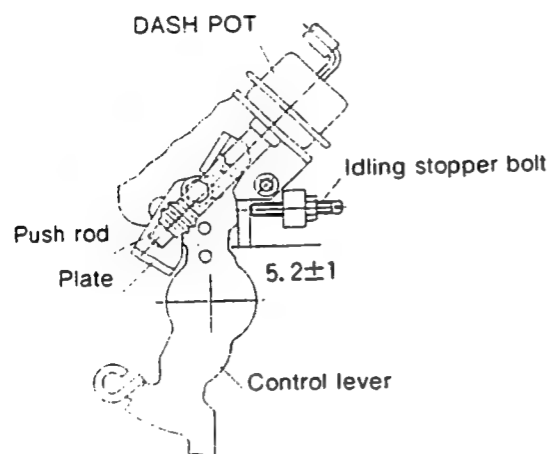

Note

- 1 At a pump speed of 1250 rpm and boost pressure of 590 mmHg, adjust the Full Load injection quantity after confirming the boost compensator stoppre's full stroke.
- 2 At a pump speed of 750 rpm and boost pressure of 250 mmHg, adjust the full load fuel injection quantity ($40.2 \sim 41.2$ cc/1000st) using the BCS spring set screw.

■ W-CSD ADJUSTMENT

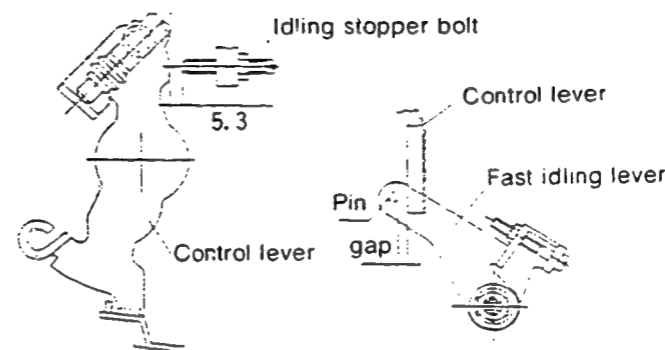

Fig. 1

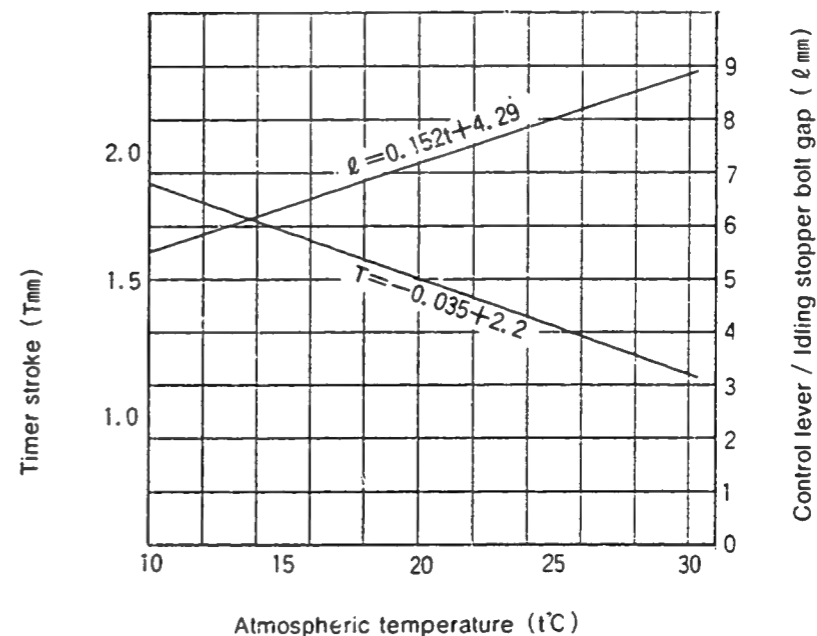

Fig. 2

1) Timer Stroke Adjustment (Refer to Fig 1.2)

- ① Using the graph (Fig 2) , determine the Timer Stroke according to the atmospheric temperature at the time of adjustment.
- ② Adjust using the Timer Stroke adjusting bolt so that the Timer Stroke corresponds to the value determined in ncte ① above.

2) Fast Idle Adjustment (Refer to Fig 1.2)

- ① Insert a block gauge of 5.3 ± 0.05 mm thickness in the gap between the control lever and the idling stopper bolt.

- ② From Fig 2 determine the dimension of the gap between the idling lever pin and the control lever according to the atmospheric temperature at the time of adjustment.
- ③ Adjust using the fast idle adjusting screw so that the gap corresponds to the value determined in note 2) ② above.

■ POTENTIOMETER ADJUSTMENT

Under the following conditions, after potentiometer installation position so that the out-put voltage equal the specified value.

Adjustment Conditions			Specified Value	Remarks
Control lever position	Pump speed (rpm)	Fuel Injection Quantity(cc/1000st)	Adjustment Value Out-put voltage (V)	
(Approx 19°)	1000	22.9	4 ± 0.03	Adjusting point
Idle	---	---	0.8 ± 0.7	Check point
Full speed	---	---	7.7 ± 1.2	Check point

[In-put Voltage: V]

※ A control lever position of approximately 19°, means that a block gauge of 12.1 mm thickness is inserted between the control lever and the idling stopper bolt.

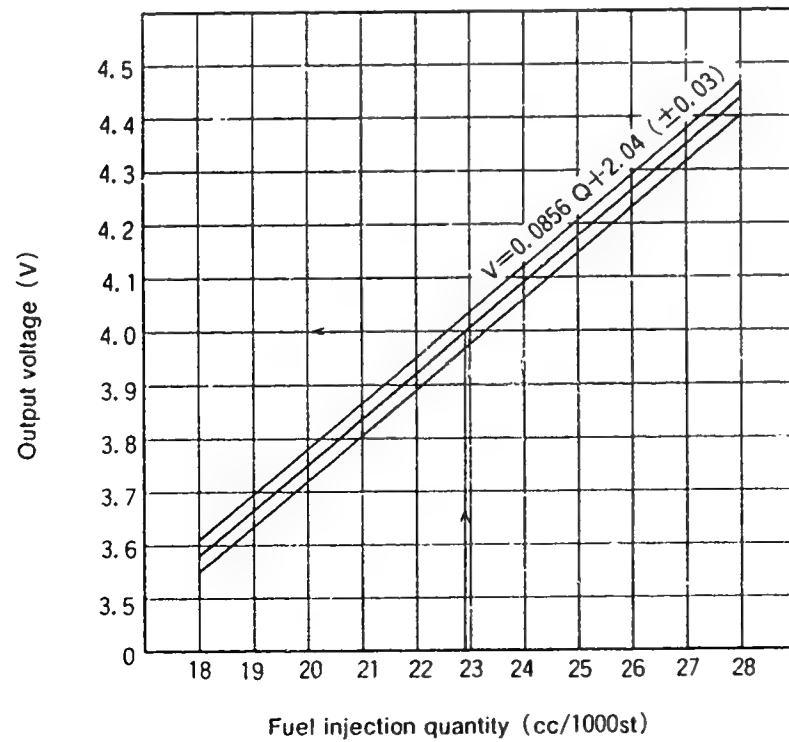

INJ. PUMP CALIBRATION DATA

Distributor-type

TEST OIL:
ISO 4113 or
SAE J967d

ENGINE MODEL : 4D65

BOSCH No. 9 460 610 322 1/4
DKKC No. 104749 - 3140
Date : 28, Oct. 1988
Company : MITSUBISHI
No. MD119828

F - 4

104749 - 3140 2/4

Injection pump No.: 104649-3090 [NP-VE4/9F2250RNP542]

Pump rotation : clockwise-viewed from drive side

For Test Condition see
Microfiche No. WP-210 (N-16)

Pre-stroke : — mm

1. Setting	Pump speed (rpm)	Settings	Charge air press (mmHg)	Difference in delivery (cc)
1-1 Timing device travel	1,250	T=3.3 ~ 3.7 (mm)	580 ~ 600	
1-2 Supply pump pressure	1,250	4.5 ~ 5.1 (kg/cm ²)	580 ~ 600	
1-3 Full load delivery without charge air pressure	1,250	43.3 ~ 44.3 (cc/1,000st)	580 ~ 600	3.5
Full load delivery with charge air pressure	750	41.2 ~ 42.2 (cc/1,000st)	240 ~ 260	3.0
1-4 Idle speed regulation	400	5.0 ~ 8.0 (cc/1,000st)	0	2.0
1-5 Start	100	43.0 ~ 63.0 (cc/1,000st)	0	
1-6 Full-load speed regulation	2,750	3.5 ~ 9.5 (cc/1,000st)	0	
1-7 Load - timer adjustment	1,250	T-0.6 ± 0.2 (mm)	0	
1-8				

2. Test Specifications

2-1 Timing device	N = rpm mm	600 0.4 ~ 1.6	1,250 3.1 ~ 3.9	2,250 7.8 ~ 8.6	
2-2 Supply pump	N = rpm kg/cm ²	600 2.9 ~ 3.5	1,250 4.5 ~ 5.1	2,250 6.8 ~ 7.4	
2-3 Overflow delivery	N = rpm cc/10s		1,250 48.0 ~ 92.0		
2-4 Fuel injection quantities	Speed control lever position	Pump speed (rpm)	Fuel delivery (cc/1,000st)	Charge air press (mmHg)	Difference in delivery (cc)
Full speed position		1,250	42.8 ~ 44.8	580 ~ 600	
		750	40.7 ~ 42.7	240 ~ 260	
		600	31.7 ~ 36.7	0	
		2,250	34.7 ~ 39.7	580 ~ 600	
		2,750	3.0 ~ 10.0	0	
		3,000	Below 3.0	0	
Switch OFF		400	0	0	
Idling position		400	Below 2.0	0	
		600	4.5 ~ 8.5	0	
2-5 Solenoid		Max. cut-in voltage: 8 V Test voltage: 12 ~ 14 V			

3. Dimensions

K	3.2 ~ 3.4	mm
KF	5.7 ~ 5.9	mm
MS	0.9 ~ 1.1	mm
BCS	2.9 ~ 3.1	mm
Control lever angle		
α	55.0 ~ 63.0	deg
A	10.5 ~ 16.0	mm
β	36.0 ~ 46.0	deg
B	10.5 ~ 15.0	mm
γ	—	deg
C	—	mm

LOAD TIMER ADJUSTMENT

1) Adjustment

① Fix the control lever in the position satisfying the following conditions.

Boost Pressure : 0 mmHg

Pump Speed : 1,250 rpm

Fuel Injection Quantity : 33.2 ± 1 cc/1000st

② With the control lever positioned as described in ① above, adjust the governor sleeve so that the Timer Stroke conforms to the specified values (Item 1/4).

Control lever position			Specified Values	
Pump speed (rpm)	Fuel Injection Quantity (cc/1000st)	Boost pressure (mmHg)	Timer stroke (mm)	Timer stroke reduction value (mm)
1,250	31.7 ~ 34.7	0	(2.9)	0.2 ~ 1.0
1,250	23.1 ~ 25.1	0	(1.7 ~ 2.9)	(1.2)

○ Note

■ When confirming timing device travel and supply pump pressure characteristics, apply boost pressure of 580 ~ 600 mmHg to the boost chamber.

■ At a pump speed of 1,250 rpm and a boost pressure of 590 mmHg, adjust the full load injection quantity after confirming the boost compensator stopper's full stroke.

■ At a pump speed of 750 rpm and a boost pressure of 250 mmHg, adjust the full load fuel injection quantity (41.2 ~ 42.2 cc/1000st) using the BCS spring set screw.



DIESEL KIKI CO., LTD.
Service Department

3-6-7 SHIBUYA, SHIBUYA-KU, TOKYO 150, JAPAN
Tel (03) 400-1551 Fax (03) 499-4115

■ DASH POT ADJUSTMENT

- 1 Insert a block gauge (thickness gauge) of thickness 5.2 ± 1 mm in the gap between the control lever and the idling stopper bolt (control lever angle: $8 \pm 2^\circ$).
- 2 With the control lever positioned as described in 1) above, adjust the plate's position so that the control lever plate and the dash pot push rod are in contact.

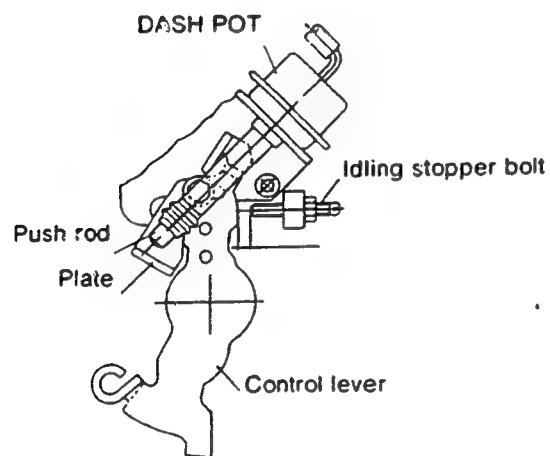

■ W-CSD ADJUSTMENT

- 1) Timer Stroke Adjustment (Refer to Fig. 1, 2)
 - ① Using the graph (Fig 2), determine the timer stroke according to the atmospheric temperature at the time of adjustment.
 - ② Adjust using the timer stroke adjusting bolt so that the timer stroke corresponds to the value determined in note ① above.
- 2) Fast Idle Adjustment (Refer to Fig. 1, 2)
 - ① Insert a block gauge of 5.2 ± 0.05 mm thickness in the gap between the control lever and the idling stopper bolt.
 - ② From Fig. 2 determine the dimension of the gap between the idling lever pin and the control lever according to the atmospheric temperature at the time of adjustment.
 - ③ Adjust using the fast idle adjusting screw so that the gap corresponds to the value determined in note 2) ②. above.

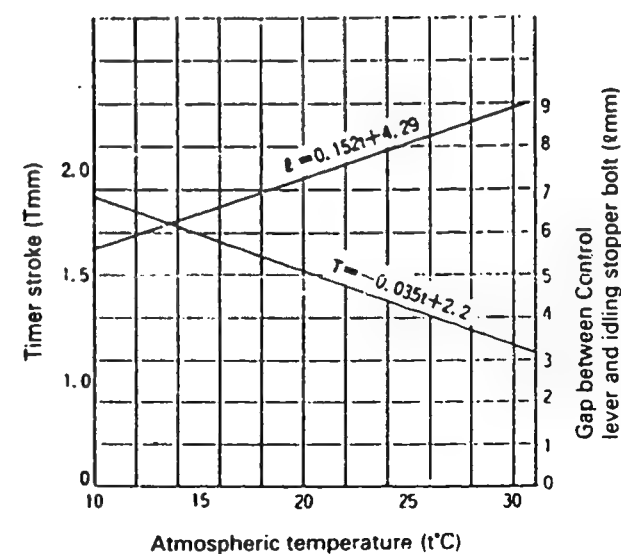
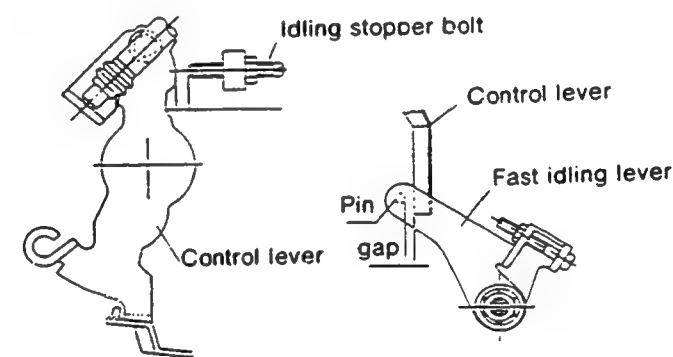

Fig. 2

INJ. PUMP CALIBRATION DATA

Distributor-type

TEST O.L:
ISO 4113 or
SAE J967d

ENGINE MODEL : 4EC1T

BOSCH No. 9 460 610 331 1/5
DKKC No. 104749 - 5000
Date : 28, Oct. 1988
Company : ISUZU
No. 8943334210

F - 6

104749 - 5000 2/5

Injection pump No. 104649-5000 [NP-VE4/9F2500RNP724]

Pump rotation : clockwise-viewed from drive side

For Test Condition see
Microfiche No. WP-210 (N-16)

Pre-stroke : — mm

1. Setting	Pump speed (rpm)	Settings	Charge air press (mmHg)	Difference in delivery (cc)
1-1 Timing device travel	1,250	T = 2.8 - 3.2 (mm)	510 - 530	
1-2 Supply pump pressure	1,250	3.9 - 4.3 (kg/cm ²)	510 - 530	
1-3 Full load delivery without charge air pressure	1,000	41.3 - 42.3 (cc/1,000st)	240 - 260	3.5
Full load delivery with charge air pressure	1,500	42.5 - 43.5 (cc/1,000st)	510 - 530	3.5
1-4 Idle speed regulation	375	6.0 - 10.0 (cc/1,000st)	0	2.0
1-5 Start	100	35.0 - 65.0 (cc/1,000st)	0	
1-6 Full-load speed regulation	2,750	13.5 - 19.5 (cc/1,000st)	510 - 530	5.5
1-7 Load - timer adjustment	2,750	T = 1.1 ± 0.2 (mm)	510 - 530	
1-8				

2. Test Specifications

2-1 Timing device	N = rpm mm)	650 0	620 0.1 - 1.3	1,250 2.7 - 3.3	2,000 5.4 - 6.6	2,250 6.6 - 7.4
2-2 Supply pump	N = rpm kg/cm ²	600 2.2 - 2.8	1,250 3.9 - 4.3	2,250 6.2 - 6.8		
2-3 Overflow delivery	N = rpm cc/10s		1,250 36.0 - 82.0			
2-4 Fuel injection quantities						
Speed control lever position	Pump speed (rpm)	Fuel delivery (cc/1,000st)	Charge air press (mmHg)	Difference in delivery (cc)		
Full speed position	1,500	42.0 - 44.0	510 - 530			
	1,000	40.8 - 42.8	240 - 260			
	600	33.3 - 38.3	0			
	1,300	42.2 - 46.2	510 - 530			
	2,300	34.6 - 38.6	510 - 530			
	2,750	13.0 - 20.0	510 - 530			
	2,950	Below 6.0	510 - 530			
Switch OFF	375	0	0			
Idling position	375	6.0 - 10.0	0			
	500	Below 3.0	0			
2-5 Solenoid	Max. cut-in voltage: 8 V Test voltage: 12 - 14 V					

3. Dimensions

K	3.2 - 3.4	mm
KF	5.7 - 5.9	mm
MS	0.8 - 1.0	mm
BCS	2.8 - 3.0	mm
Control lever angle		
α	16.0 - 24.0	deg
A	11.2 - 13.8	mm
β	40.0 - 50.0	deg
B	12.9 - 16.1	mm
γ	—	deg
C	—	mm

LOAD TIMER ADJUSTMENT

1) Adjustment

- Fix the control lever in the position satisfying the following conditions.

Boost Pressure : 510 - 530 mmHg
Pump Speed : 2,750 rpm
Fuel injection Quantity : 35.4 ± 0.5 cc/1000st

- With the control lever positioned as described in 1) above, adjust the governor sleeve so that the Timer Stroke conforms to the specified values (Item 1/5).

Control lever position			Specified Values	
Pump speed (rpm)	Fuel Injection Quantity (cc/1000st)	Boost pressure (mmHg)	Timer stroke (mm)	Timer stroke reduction value (mm)
1,250	35.4 ± 1	510 - 530	—	1.1 ± 0.3
1,250	27.1 ± 1.5	510 - 530	—	1.5 ± 0.5

○ Note

- When confirming timing device travel and supply pump pressure characteristics, apply boost pressure of 510 - 530 mmHg to the boost chamber.

○ Note

- After adjustment of full load fuel injection quantity (1,500 rpm, 42.5 - 43.5 cc/1000st), set the boost pressure at 240 - 260 mmHg, and at a pump speed of 1000 rpm adjust the fuel injection quantity using the BCS spring set screw.

■ V — FICD Adjustment (adjust with W — CSD released)

1) V — FICD installation position adjustment.

1. Fix the control lever in the idling position.
2. Adjust the position of the V — FICD bracket so that the gap "S" between the actuator shaft and the pin press-fitted to the control lever is 1 ± 1 mm.

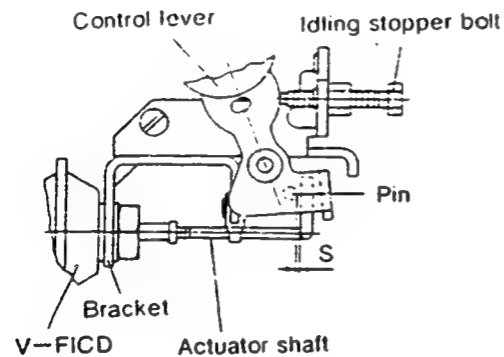

2) V — FICD Stroke Adjustment

1. Hold the control lever in the idling position.
 2. Apply a negative pressure of 350 mmHg to the inside of the actuator.
 3. Adjust using the stroke adjusting screw so that the clearance "ℓ" between the control lever and the idling stopper bolt is 1.6 ± 0.1 mm.
 4. After adjusting, tighten securely using the locknut.
- Tightening torque: 0.12 – 0.15 kg-m.

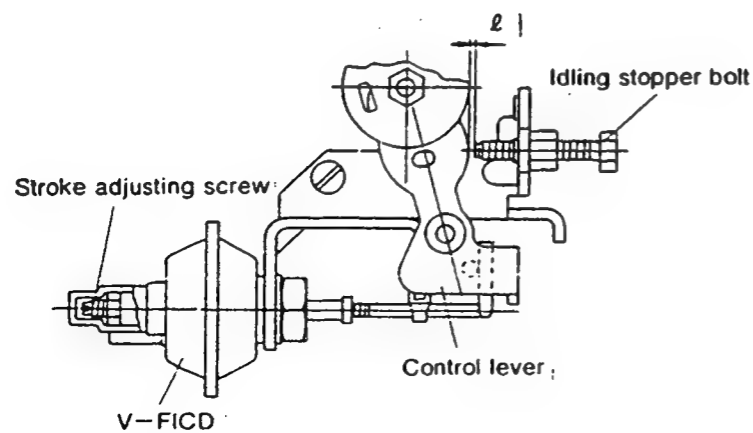

■ W — CSD Adjustment

1) Timer Stroke Adjustment (adjust to the thick line)

1. Calculate the timer stroke from Fig. 2 according to the atmospheric temperature at the time of adjustment.

2) Intermediate Lever Position Adjustment.

1. Insert a block gauge (thickness gauge) of 1.2 ± 0.05 mm thickness between the control lever and the idling stopper bolt.
2. Align the intermediate lever with the aligning mark.
3. Adjust the intermediate lever set screw so that the control lever and the intermediate lever set screw are in contact, and then fix in position using the locknut.

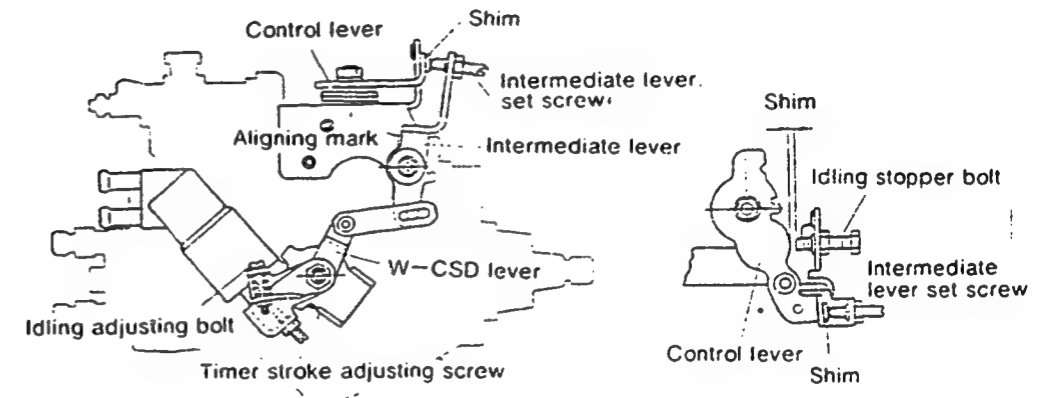

Fig. 1

3) CSD Lever Adjustment (adjust to the thick line)

1. Calculate the block gauge dimension $l \pm 0.05$ mm from Fig. 2 according to the atmospheric temperature at the time of adjustment.
2. Insert the block gauge (thickness gauge) between the control lever and the idling stopper bolt.
3. Using the idling bolt, adjust so that the CSD lever roller and the intermediate lever are in contact.

Formula for calculating Fig. 2

Formula for calculating timer stroke:

$$T = -0.0235t + 1.17$$

Formula for calculating control lever and idling stopper bolt gap:

When $-20^{\circ}\text{C} \leq t \leq 20^{\circ}\text{C}$ $l = -0.02075t + 1.585$

When $20^{\circ}\text{C} \leq t \leq 50^{\circ}\text{C}$ $l = -0.039t + 1.95$

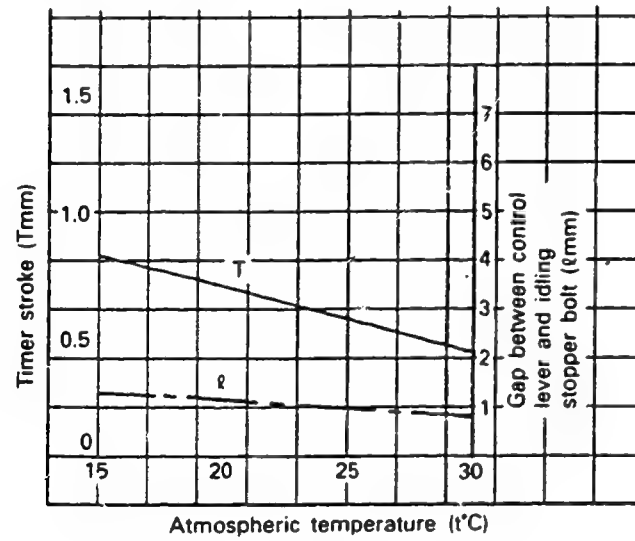

Fig. 2

INJ. PUMP CALIBRATION DATA

Distributor-type

TEST OIL:
ISO 4113 or
SAE J967d

ENGINE MODEL : C223

Injection pump No.: 104649-6971 [NP-VE4/9F2175RNP676]

BOSCH No. 9 460 610 332 1/2
DKKC No. 104749 - 6971
Date : 28, Oct. 1988
Company : ISUZU
No. 8944751850

F - 9

104749 - 6971 2/2

Pump rotation : clockwise-viewed from drive side

For Test Condition see
Microfiche No. WP-210 (N-16)

Pre-stroke : — mm

1. Setting	Pump speed (rpm)	Settings	Charge air press (mmHg)	Difference in delivery (cc)
1-1 Timing device travel	1,500	4.2 ~ 4.6 (mm)		
1-2 Supply pump pressure	1,500	5.2 ~ 5.6 (kg/cm ²)		
1-3 Full load delivery without charge air pressure	1,250	35.8 ~ 36.8 (cc/1,000st)		3.0
Full load delivery with charge air pressure		(cc/1,000st)		
1-4 Idle speed regulation	375	5.6 ~ 9.6 (cc/1,000st)		2.0
1-5 Start	100	Above 63 (cc/1,000st)		
1-6 Full-load speed regulation	2,550	7.8 ~ 13.8 (cc/1,000st)		3.0
1-7 CSD Adjustment	500 ~ 700	Release speed		
1-8				

2. Test Specifications

2-1 Timing device	N = rpm mm	1,000 1.6 ~ 2.8	1,500 4.1 ~ 4.7	2,175 7.0 ~ 7.8
2-2 Supply pump	N = rpm kg/cm ²	1,000 3.8 ~ 4.4	1,500 5.2 ~ 5.6	2,175 6.6 ~ 7.2
2-3 Overflow delivery	N = rpm cc/10s	1,000 48.0 ~ 92.0		
2-4 Fuel injection quantities				
Speed control lever position	Pump speed (rpm)	Fuel delivery (cc/1,000st)	Charge air press (mmHg)	Difference in delivery (cc)
Full speed position	1,250	35.3 ~ 37.3		
	600	29.7 ~ 33.7		
	2,175	32.0 ~ 36.2		
	2,550	7.3 ~ 14.3		
	2,700	Below 3.5		
Switch OFF	375	0		
Idling position	375	5.6 ~ 9.6		
	500	Below 3.0		
CSD Adjustment	0 500 ~ 700	2.7 ~ 3.1 mm Release speed		
2-5 Solenoid	Max. cut-in voltage: 8 V Test voltage: 12 ~ 14 V			

3. Dimensions

K	3.2 ~ 3.4	mm
KF	5.7 ~ 5.9	mm
MS	1.7 ~ 1.9	mm
BCS	—	mm
Control lever angle		
α	21.0 ~ 29.0	deg
A	9.6 ~ 12.2	mm
β	37.0 ~ 47.0	deg
B	11.9 ~ 15.1	mm
γ	—	deg
C	—	mm

■ CSD Adjustment

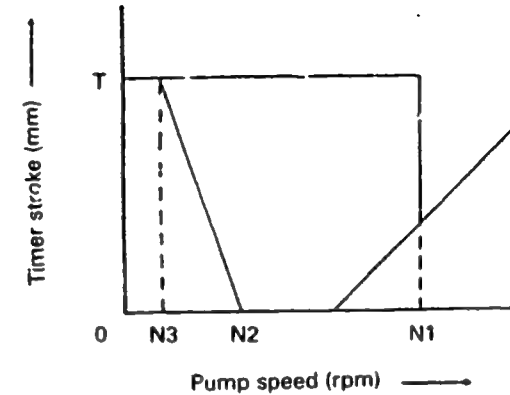

Standard values

N1 (Release speed) 500 ~ 700 rpm

N2 Less than 225 rpm

T 2.7 ~ 3.1 mm

1) Bleeding of Air

1. Run the pump at N1 or above.
2. Gradually decrease the pump speed and check the 0 point of the measuring device.
3. Run the pump at a speed midway between N2 and N3.
4. Check that the test oil flows from the CSD overflow.

2) Adjustment

1. Check that the timer stroke is T when the pump is stopped.
2. Adjust the shim thickness so that at the CSD release point the timer piston begins moving in the timer stroke decrease direction at a pump speed of 600 ± 100 rpm.
3. Gradually decrease the pump speed and check that the CSD begins to operate at speeds less than N2.

Note:

When measuring the release speed, check that there is no leakage from the CSD overflow.

INJ. PUMP CALIBRATION DATA

Distributor-type

TEST OIL:
ISO 4113 or
SAE J967d

ENGINE MODEL : 6D95L

BOSCH No. 9 460 610 321
DKKC No. 104761 - 4022
Date : 28, Oct. 1988
Company : KOMATSU
No. 6206711191

F - 10

Injection pump No.: 104661-4022 [NP--VE6/11F1125RNP37]

Pump rotation : clockwise-viewed from drive side

For Test Condition see
Microfiche No. WP-210 (N-16)

Pre-stroke : — mm

1. Setting		Pump speed (rpm)	Settings	Charge air press (mmHg)	Difference in delivery (cc)
1-1	Timing device travel	At all pump speeds	0 (Fixed 5°) (mm)		
1-2	Supply pump pressure	250	0.6 ~ 1.0 (kg/cm ²)		
1-3	Full load delivery without charge air pressure	750	45.8 ~ 46.8 (cc/1,000st)		3.0
	Full load delivery with charge air pressure		(cc/1,000st)		
1-4	Idle speed regulation	350	10.2 ~ 14.2 (cc/1,000st)		2.0
1-5	Start	100	Above 85 (cc/1,000st)		
1-6	Full-load speed regulation	1,225	7.9 ~ 13.9 (cc/1,000st)		4.5
1-7					
1-8					

2. Test Specifications

2-1	Timing device	N = rpm mm			
2-2	Supply pump	N = rpm kg/cm ²	250 0.6 ~ 1.0	750 2.1 ~ 3.3	
2-3	Overflow delivery	N = rpm cc/10s	750 30.0 ~ 73.3		
2-4	Fuel injection quantities				
	Speed control lever position	Pump speed (rpm)	Fuel delivery (cc/1,000st)	Charge air press(mmHg)	Difference in delivery (cc)
	Full speed position	750	45.3 ~ 47.3		
		500	42.6 ~ 47.6		
		1,125	38.2 ~ 43.2		
		1,225	7.4 ~ 14.4		
		1,300	Below 3.0		
	Switch OFF	100 350	Below 18 (Full) 0 (Idle)		
	Idling position	200	37.3 ~ 47.3		
		250	28.3 ~ 38.3		
		350	10.2 ~ 14.2		
		450	Below 3.0		
2-5	Solenoid	Max. cut-in voltage: 24 V Test voltage:			

3. Dimensions

K	2.7 ~ 2.9	mm
KF	4.9 ~ 5.1	mm
MS	1.1 ~ 1.3	mm
BCS	—	mm
Control lever angle		
α	21.0 ~ 29.0	deg
A	2.5 ~ 7.7	mm
β	35.0 ~ 45.0	deg
B	10.1 ~ 14.1	mm
γ	—	deg
C	—	mm



DIESEL KIKI CO., LTD.
Service Department

3-6-7 SHIBUYA SHIBUYA-KU, TOKYO 150, JAPAN
Tel (03) 400-1551-Fax (03) 499-4115

INJ. PUMP CALIBRATION DATA

Distributor-type

TEST OIL:
ISO 4113 or
SAE J967d

ENGINE MODEL : LD28

BOSCH No. 9 460 610 232 1/5
DKKC No. 104769 - 2063
Date : 28, Oct. 1988
Company : NISSAN
No. 16700 50L05

F - 11

104769 - 2063 2/5

Injection pump No.: 104669-2121 [NP-VE6/9F2500RNP32]

Pump rotation : clockwise-viewed from drive side

For Test Condition see
Microfiche No. WP-210 (N-16)

Pre-stroke : — mm

1. Setting		Pump speed (rpm)	Settings	Charge air press (mmHg)	Difference in delivery (cc)
1-1	Timing device travel	900	T = 2.0 - 2.6 (mm)		2.5
1-2	Supply pump pressure	900	3.5 - 4.1 (kg/cm ²)		
1-3	Full load delivery without charge air pressure	900	29.0 - 30.0 (cc/1,000st)		
	Full load delivery with charge air pressure		(cc/1,000st)		
1-4	Idle speed regulation	350	6.3 - 9.3 (cc/1,000st)		
1-5	Start	100	40.8 - 48.8 (cc/1,000st)		
1-6	Full-load speed regulation	2,600	15.5 - 21.5 (cc/1,000st)		
1-7	Load - timer adjustment	900	T - 0.5 ± 0.3 (mm)		
1-8					

2. Test Specifications

2-1	Timing device	N = rpm mm	900 1.9 - 2.7	1,200 3.5 - 4.7	2,300 8.1 - 9.0
2-2	Supply pump	N = rpm kg/cm ²	900 3.4 - 4.2	1,800 5.5 - 6.3	2,500 7.2 - 8.0
2-3	Overflow delivery	N = rpm cc/10s	900 43.0 - 87.0		
2-4	Fuel injection quantities				
	Speed control lever position	Pump speed (rpm)	Fuel delivery (cc/1,000st)	Charge air press (mmHg)	Difference in delivery (cc)
	Full speed position	900	28.5 - 30.5		
		600	27.0 - 31.0		
		2,300	28.8 - 32.8		
		2,600	15.0 - 22.0		
		2,800	Below 5.0		
	Switch OFF	350	0		
	Idling position	350	5.8 - 9.8		2.2
		500	Below 4.0		
	Partial load	900	2.1 - 12.1		
2-5	Solenoid	Max. cut-in voltage: 8 V Test voltage: 12 - 14 V			

3. Dimensions

K	3.20 - 3.40	mm
KF	6.54 - 6.74	mm
MS	1.70 - 1.90	mm
BCS	—	mm
Control lever angle		
α	21.0 - 29.0	deg
A	5.7 - 9.5	mm
β	39.0 - 49.0	deg
B	11.0 - 16.0	mm
γ	10.5 - 11.5	deg
C	4.8 - 5.2	mm

Starting Injection Quantity Adjustment

Adjust the starting injection quantity (item 1/5) using the adjusting bolt (as shown in the figure at right)

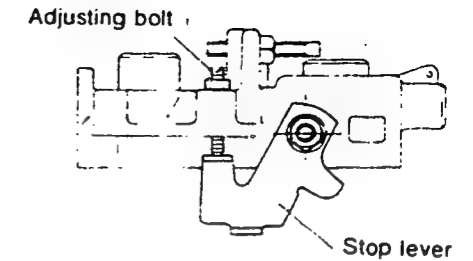

LOAD TIMER ADJUSTMENT

1) Adjustment

① Fix the control lever in the position satisfying the following conditions.

Boost Pressure : — mmHg

Pump Speed : 900 rpm

Fuel Injection Quantity : 9 ± 1 cc/1000st

② With the control lever positioned as described in ① above, adjust the governor sleeve so that the Timer Stroke conforms to the specified values (Item 1/7).



DIESEL KIKI CO., LTD. 3-6-7 SHIBUYA, SHIBUYA-KU, TOKYO 150, JAPAN
Service Department Tel (03) 400-1551 Fax (03) 499-4115

■ W — CSD Adjustment

1) Timer stroke adjustment

1. Calculate the timer stroke from Fig. 2 according to the atmospheric temperature at the time of adjustment.
2. Adjust using timer stroke adjusting screw so that the timer stroke is as calculated in Step. 1.

2) Intermediate lever position adjustment

1. Insert a block gauge (thickness gauge) of 0.9 ± 0.05 mm thickness between the control lever and the idling stopper bolt.
2. Align the intermediate lever with the aligning mark.
3. Adjust the intermediate lever set screw so that the control lever and intermediate lever set screw are in contact, and then fix in position using the locknut.

3) CSD lever adjustment

1. Calculate the block gauge dimension $\ell \pm 0.05$ mm from Fig. 2 according to the atmospheric temperature at the time of adjustment.
2. Insert the block gauge (thickness gauge) between the control lever and the idling stopper bolt.
3. Using the idling bolt, adjust so that the CSD lever roller and intermediate lever are in contact.

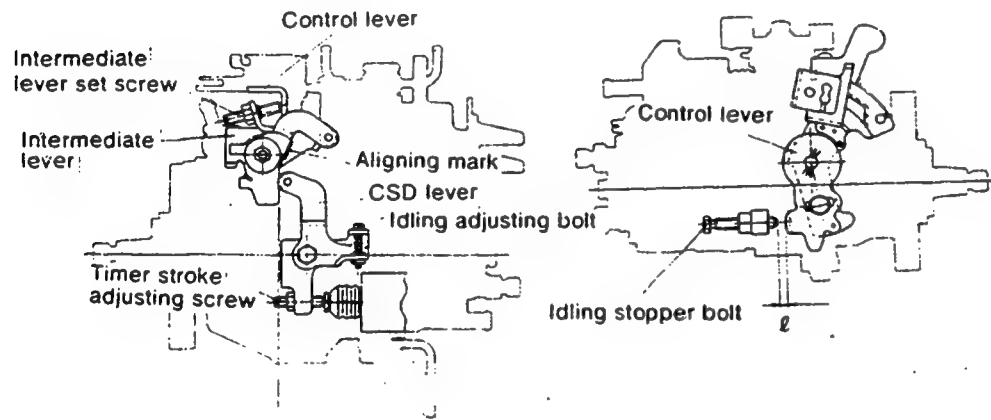

Fig. 1

Formula for calculating Fig. 2

Formula for calculating timer stroke:

When $-10 \leq t \leq 20$ $T = -0.0367 t + 1.284$

When $20 \leq t \leq 40$ $T = -0.0275 t + 1.1$

Formula for calculating control lever and idling stopper bolt gap:

When $-10 \leq t \leq 20$ $\ell = -0.0628 t + 2.1555$

When $20 \leq t \leq 30$ $\ell = -0.0507 t + 1.9142$

When $30 \leq t \leq 50$ $\ell = -0.0196 t + 0.9809$

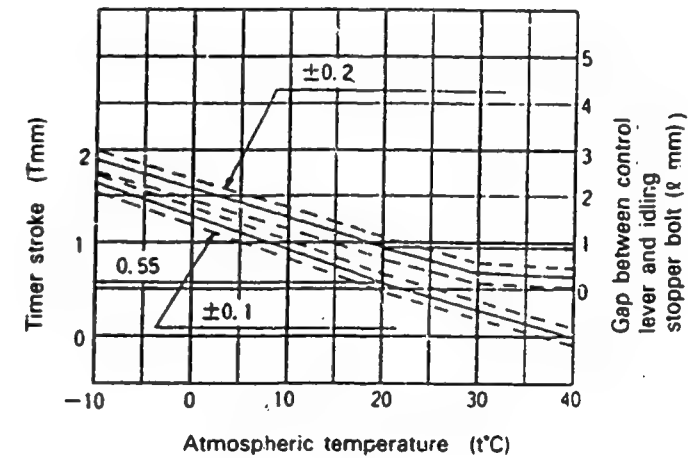

Fig. 2

Notes:

1. The temperature of the wax must be below 30°C when adjusting.
2. When inserting a block gauge (thickness gauge) between the control lever (bracket) and the idling stopper bolt, use the idling adjusting bolt to separate the CSD lever and intermediate lever so that no excessive force is exerted on them.

■ DASH POT ADJUSTMENT

1. Insert a block gauge (thickness gauge) of thickness 3.4 ± 0.05 in the gap between the idling stopper bolt and the bracket.
2. With the control lever positioned as described in ① above, adjust the Dashpot adjusting screw so that the Dashpot adjusting screw and the push rod are in contact. Fix using the nut.

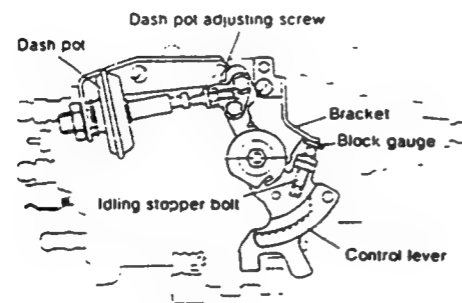

INJ. PUMP CALIBRATION DATA

ENGINE MODEL 6D22T

BOSCH No. 9 400 610 071 1/4
 DKKC No. 106671 - 2941
 Date : 28, Oct. 1988 ①
 Company : MITSUBISHI
 No. ME059626

F - 14

106671 - 2941 2/4

Injection pump : PE6P Governor : EP/RSV Timing device : EP/SP
 106060-5140 105408-0300 105636-1150

1. Test Conditions :

Pump rotation : clockwise viewed from drive side

Nozzle & Nozzle Holder Ass'y : 105780-0000 (BOSCH Type No. DN12SD12T)
 Nozzle Holder : 105780-2080 (BOSCH Type No. EF8511/9A)
 Nozzle opening pressure : 175 kg/cm²
 Transfer pump pressure : 1.6 kg/cm²
 Injection pipe : Inner Dia. 3 mm x Outer Dia. 8 mm - Length 600 mm

Test Oil : ISO4113 or SAE Standard Test Oil (SAE J967d) Oil Temp. : 40 °C
 Overflow valve opening pressure : 2.6 kg/cm²

2. Injection Timing :

Pre-stroke : No. 1 Plunger 4.8 ± 0.05 mm

Note : Adjust with control rod position of mm

Injection order : 1 - 5 - 3 - 6 - 2 - 4 (interval : 60° ± 30')

Plungers are numbered from the Drive side.

Tappet clearance : Bolt adjustment type ; More than 0.3 mm for all cylinders.

4. Injection Quantity :

Adjusting Point	Rod Position (mm)	Pump Speed (r.p.m.)	Injection Q'ty (cc/1000 strokes)	Max. var bet. cyl (%)	Fixed	Remarks
A	9.7	700	72.0 ~ 78.0	± 3	Rack	Basic
B	(5.8)	500	12.4 ~ 17.6	± 15	Rack	
A	9.7	700	72.0 ~ 78.0	-	Lever	Basic
C	Approx. 13.9	100	113.0 ~ 153.0	-	Lever	Control rack limit
D	Approx. 6.9	225	12.4 ~ 17.6	-	Rack	(Confirmation)

5. Timing Advance Specification :

Pump Speed (r.p.m.)	Below 650	600	900	1,000			
Advance Angle (deg)	Start	Below (0.5)	(1.1 ~ 2.1)	(1.7 ~ 2.7)	Finish 2.5 ~ 3.5		

3. GOVERNOR ADJUSTMENT

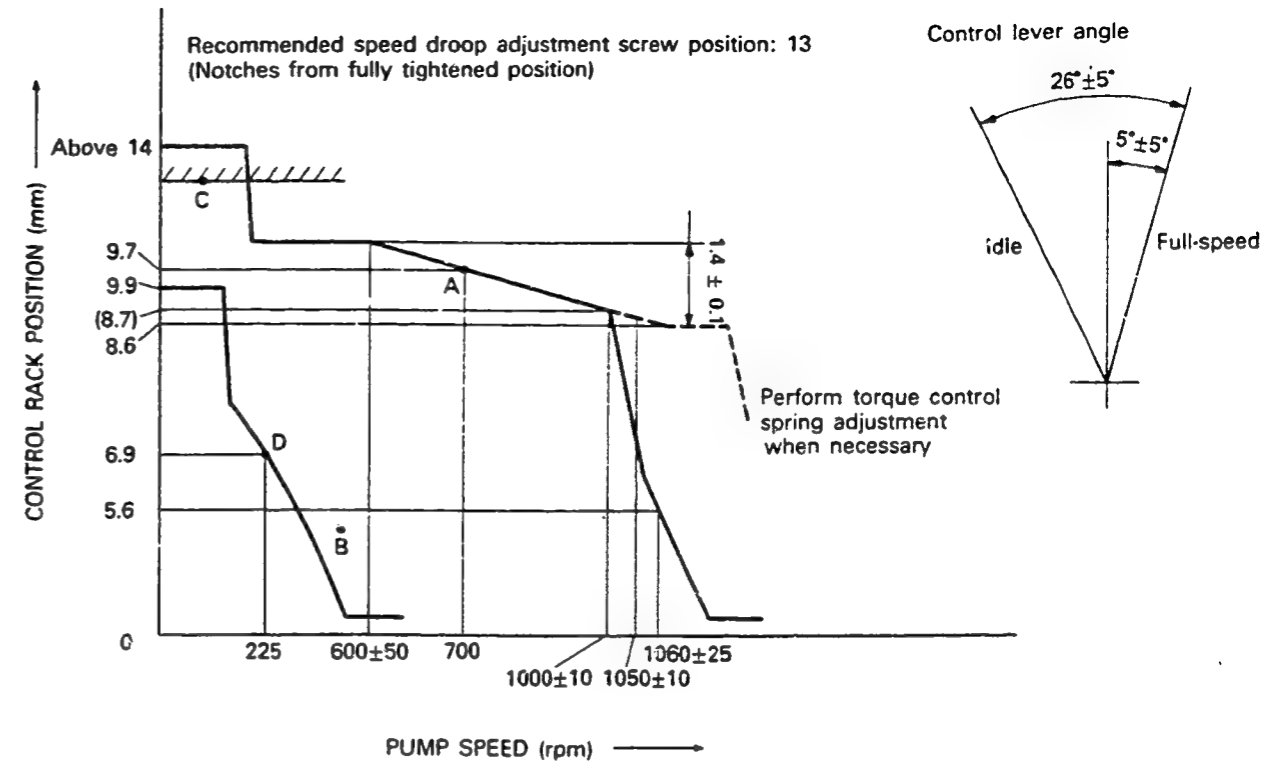

Note

- Before adjustment, remove the idling sub spring and the torque control spring.
- Move the control lever fully in the stop direction, and set the minimum-speed stopper bolt so that the control rack position is 0.5 ~ 1.0 mm.

Adjustment

Item	Pump Speed (rpm)	Rack Position (mm)	Remarks
Full-load Adjustment (Temporary)	1040 ~ 1060	8.6	• Adjust using screw ① • Adjust using screw ②
	500	9.9 ~ 10.1	• Adjust using spring capsule ①
Torque Control Spring Adjustment	550 ~ 650	9.9 ~ 10.1	• Confirm
	1040 ~ 1060	8.6	• Confirm
			• Confirm the torque control stroke is 1.3 ~ 1.5 mm.

Item	Pump Speed (rpm)	Rack Position (mm)	Remarks
Idling Adjustment	0	9.9	<ul style="list-style-type: none"> • Fix the control lever • Adjust using spring capsule ② • Confirm
	225	6.9	
	—	—	
Maximum-speed Adjustment	990 ~ 1010	(8.7)	<ul style="list-style-type: none"> • Adjust using screw ① • Confirm speed droop • Confirm • Confirm
	1035 ~ 1085	5.6	
Full-load Adjustment (Install the cover on governor cover)	700	9.7	<ul style="list-style-type: none"> • Adjust using screw ③
Control Lever Angle Measurement	<ul style="list-style-type: none"> • Measure the control lever angle at the "idling" and "full" positions. • When the control lever is depressed toward the "full" position, replace the shifter's shim with a thicker one. • When the control lever is depressed toward the "idling" position, replace the shifter's shim with a thinner one. 		
Rack Limiter Adjustment	100	Approx. 13.9	<ul style="list-style-type: none"> • Adjust using screw

■ Timing Setting

At No. 1 plunger's beginning of injection position

B.T.D.C.:

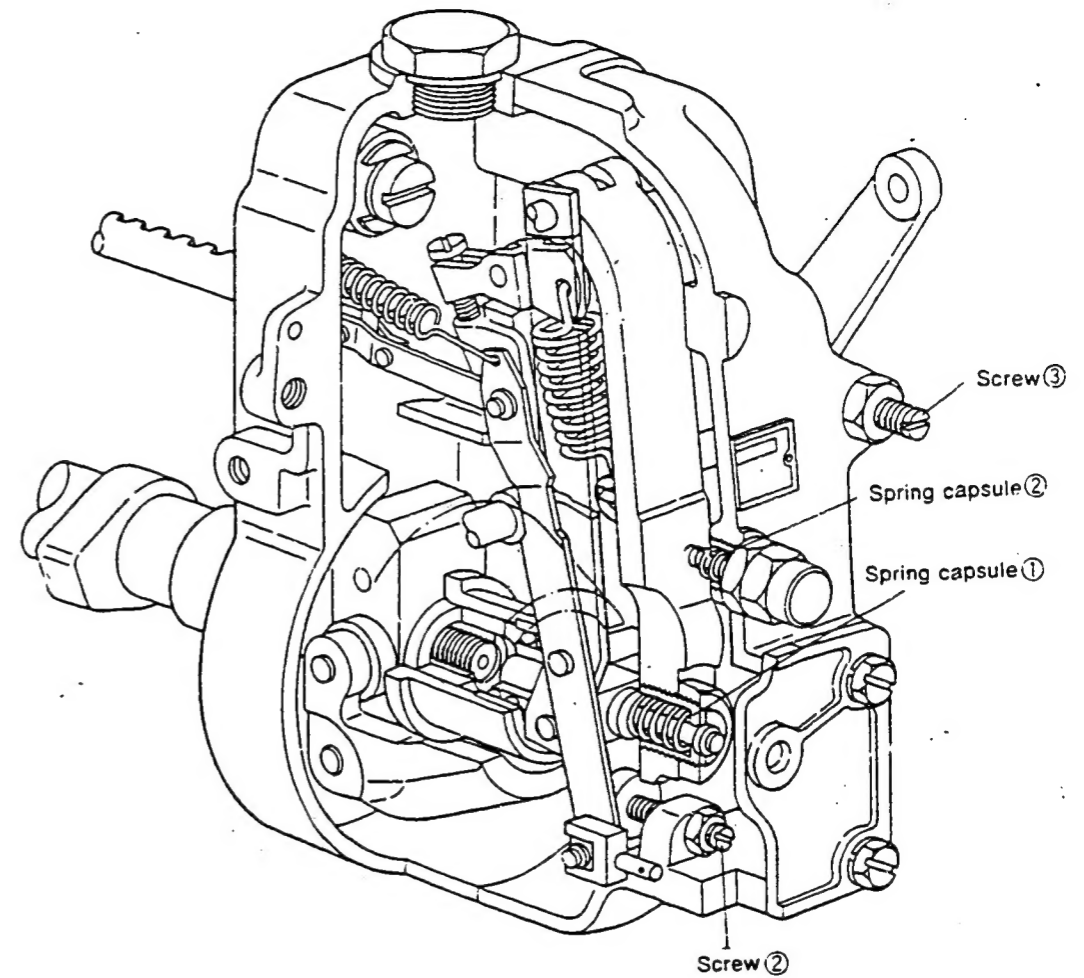
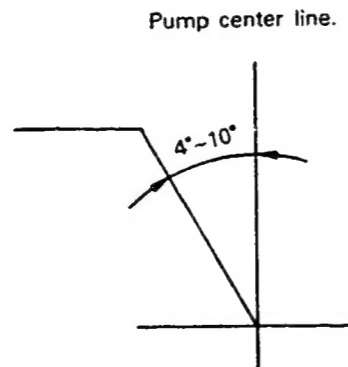

INJ. PUMP CALIBRATION DATA

ENGINE MODEL EK100

BOSCH No. 9 400 610 084 1/4
 DKKC No. 106671 - 3252
 Date : 28, Oct. 1988
 Company : HINO
 No. 22000-1494A

Injection pump : PE6P 106060-5720 Governor : EP/RFD 105488-9800 Timing device : EP/SP 105635-0041

1. Test Conditions :

Pump rotation : Counter clockwise viewed from drive side

Nozzle & Nozzle Holder Ass'y : 105780-0000 (BOSCH Type No. DN12SD12T) Nozzle Holder : 105780-2080 (BOSCH Type No. EF8511/9A)
 Nozzle opening pressure : 175 kg/cm² Transfer pump pressure : 1.6 kg/cm²
 Injection pipe : Inner Dia. 2 mm x Outer Dia. 6 mm — Length 600 mm

Test Oil : ISO4113 or SAE Standard Test Oil (SAE J967d) Oil Temp. : 40^{±5}C

Overflow valve opening pressure : 1.5 ~ 1.8 kg/cm²

2. Injection Timing :

Pre-stroke : No. 1 Plunger 3.3 - 0.06 mm

Note : Adjust with control rod position of mm

Injection order : 1 $\frac{60^{\circ} \pm 30' }{425 \pm 20}$ 4, 1 $\frac{120^{\circ} \pm 30' }{580 \pm 50}$ 2, 1 $\frac{180^{\circ} \pm 30' }{800 \pm 50}$ 6, 1 $\frac{240^{\circ} \pm 30' }{1150^{+30}_{-20}}$ 3, 1 $\frac{300^{\circ} \pm 30' }{\text{Below } 1260}$ 5 (interval: $^{\circ} \pm 30'$)

Plungers are numbered from the Drive side.

Tappet clearance : Bolt adjustment type ; More than 0.3 mm for all cylinders.

4. Injection Quantity :

Adjusting Point	Rod Position (mm)	Pump Speed (r.p.m.)	Injection Q'ty (cc/1000 strokes)	Max. var bet. cyl (%)	Fixed	Remarks
A	10.5	700	139.2 ~ 143.2	± 2	Rack	Basic
H	Approx. 7.0	225	13.0 ~ 19.0	± 15	Rack	
A	10.5	700	139.2 ~ 143.2	—	Lever	Basic
B	9.9	500	122.5 ~ 128.5	—	Lever	
C	10.8	1,150	146.7 ~ 152.7	—	Lever	
D	—	100	135.0 ~ 155.0	—	Lever	(Control rack limit)

5. Timing Advance Specification :

Pump Speed (r.p.m.)	650 ~ 750	900	1,150				
Advance Angle (deg)	Start	0.9 ~ 1.9	Finish 3.5 ~ 4.5				

3. GOVERNOR ADJUSTMENT

G - 1

106671 - 3252 2/4

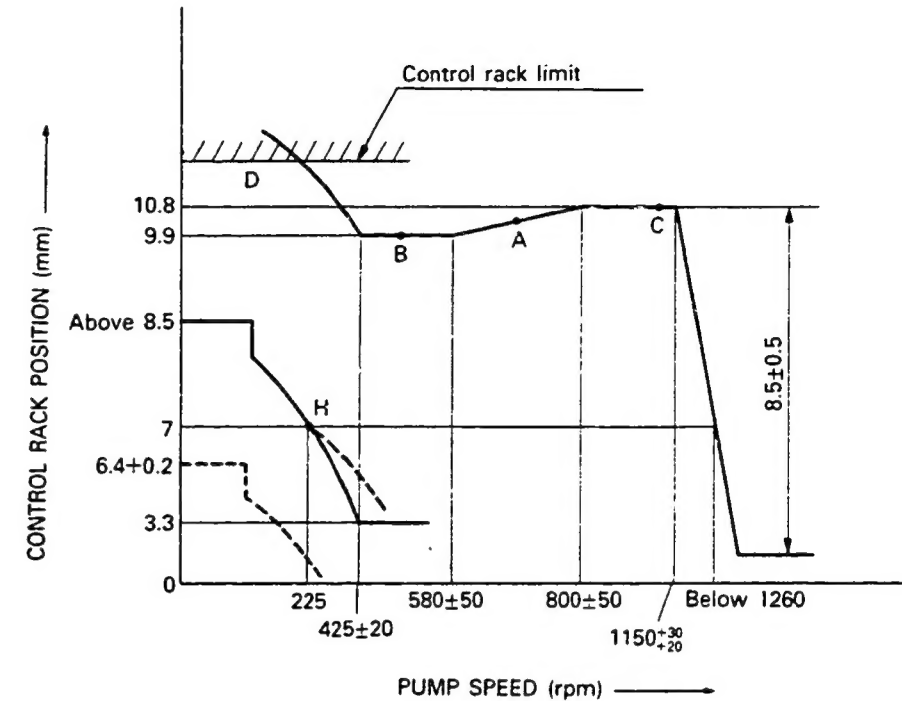

• LOAD CONTROL LEVER ANGLE

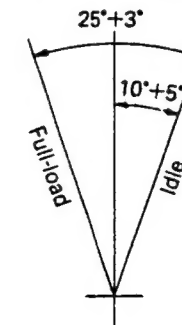

• SPEED CONTROL LEVER ANGLE

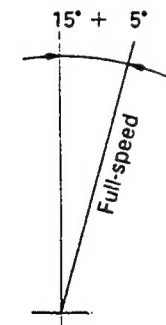

■ Note

Before adjustment, remove the damper spring, the cover and the idling spring capsule.

■ Adjustment

Item	Pump Speed (rpm)	Rack Position (mm)	Remarks
Flyweight Lift And Full-Load Position	700 ~ 800	10.8 0.1 ~ 0.2	<ul style="list-style-type: none"> • Speed control lever: temporary setting. • Adjust using screw ①.
	Decrease pump speed to (8.5 + 0.5) using screw ②.		rpm and adjust the high speed lift value
Idling Adjustment	405 ~ 445	3.3	<ul style="list-style-type: none"> • Adjust using screw ③. • Adjust using spring capsule ① • Confirm • Confirm • Confirm the control lever angle is (5° ~ 15°)
	225	7.0	
	405 ~ 445	3.3	
	225	7.0	
Damper Spring Setting	Maintain the pump speed at 225 rpm and set the control rod at the 7.0 mm position using the control lever. Then, gradually increase the pump speed until the rod position is 6.2 ^{-0.2} mm. Tighten the damper spring capsule and fix it in the position where it begins to move the rod from the 6.2 ^{-0.2} mm position.		
Maximum Speed Starting Point and Speed Droop Check	Fix the load control lever in the full-load position and fix the speed control lever in the full-speed position.		
	1150: $\frac{30}{20}$ Below 1260 Approx. 1260	10.8 7.0 —	<ul style="list-style-type: none"> • Adjust using screw ④ • Confirm • Confirm that there is no fuel injection.
Smoke Limiter Setting	Fix the load control lever in the full-load position.		
	— 100	— —	<ul style="list-style-type: none"> • Adjust using smoke limiter. • Confirm injection quantity at point D.

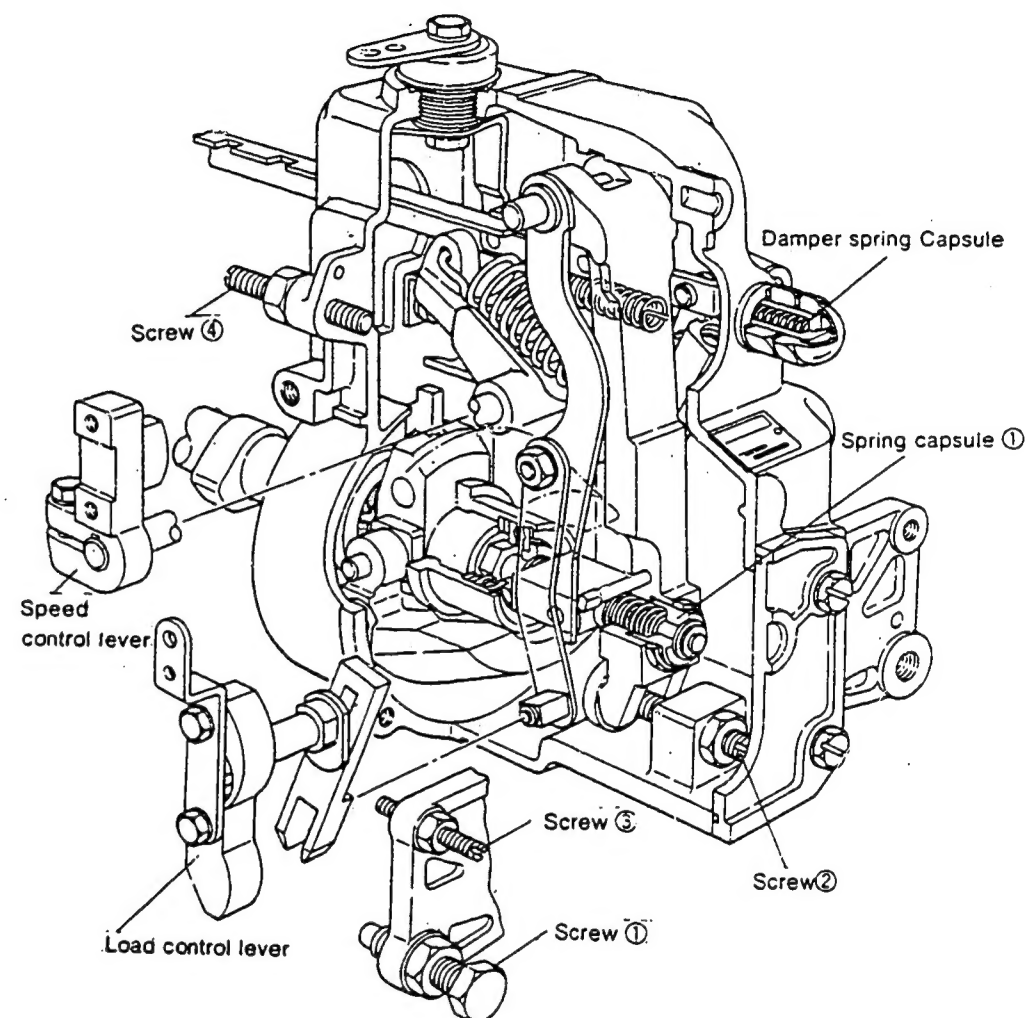

Table of Contents (DKKC No. → BOSCH No.)

Table of Contents (BOSCH No. → DKKC No.)

DKKC No.	BOSCH No.	Location	DKKC No.	BOSCH No.	Location
101342-0180	9400610079	WP-217B- 1 ~ B- 2	104749-6971	9460610332	WP-217F- 9
101431-0790	9400610054	WP-217B- 3 ~ B- 4	104761-4022	9460610321	WP-217F-10
101432-0160	9400610080	WP-217B- 5 ~ B- 6	104769-2063	9460610232	WP-217F-11 ~ F-13
101432-0220	9400610050	WP-217B- 7 ~ B- 8	106671-2941	9400610071	WP-217F-14 ~ F-15
101433-9210	9400610064	WP-217B- 9 ~ B-10	106671-3252	9400610084	WP-217G- 1 ~ G- 2
101441-9161	9400610073	WP-217B-11 ~ B-13			
101441-9171	9400610074	WP-217B-14 ~ B-16			
101441-9420	9400610075	WP-217C- 1 ~ C- 2			
101441-9430	9400610076	WP-217C- 3 ~ C- 4			
101441-9490	9400610077	WP-217C- 5 ~ C- 7			
101441-9500	9400610078	WP-217C- 8 ~ C-10			
101461-0201	9400610062	WP-217C-11 ~ C-12			
101601-6781	9400610081	WP-217C-13 ~ C-14			
101641-9143	9400610065	WP-217D- 1 ~ D- 3			
101641-9190	9400610067	WP-217D- 4 ~ D- 6			
104740-0102	9460610320	WP-217D- 7			
104740-0201	9460610213	WP-217D- 8			
104740-3671	9460610275	WP-217D- 9			
104740-3681	9460610276	WP-217D-10			
104740-3691	9460610277	WP-217D-11			
104740-4560	9460610251	WP-217D-12			
104741-1084	9460610323	WP-217D-13			
104741-1181	9460610324	WP-217D-14			
104748-0051	9460610216	WP-217D-15 ~ D-16			
104748-0222	9460610214	WP-217E- 1 ~ E- 2			
104748-0242	9460610230	WP-217E- 3 ~ E- 5			
104748-1780	9460610330	WP-217E- 6 ~ E- 8			
104748-2451	9460610257	WP-217E- 9 ~ E-11			
104749-2240	9460610196	WP-217E-12 ~ E-13			
104749-2260	9460610250	WP-217E-14 ~ E-15			
104749-3030	9460610217	WP-217F- 1 ~ F- 3			
104749-3140	9460610322	WP-217F- 4 ~ F- 5			
104749-5000	9460610331	WP-217F- 6 ~ F- 8			

BOSCH No.	DKKC No.	Location	BOSCH No.	DKKC No.	Location
9400610050	101432-0220	WP-217B- 7 ~ B- 8	9460610323	104741-1084	WP-217D-13
9400610054	101431-0790	WP-217B- 3 ~ B- 4	9460610324	104741-1181	WP-217D-14
9400610062	101461-0201	WP-217C-11 ~ C-12	9460610330	104748-1780	WP-217E- 6 ~ E- 8
9400610064	101433-9210	WP-217B- 9 ~ B-10	9460610331	104749-5000	WP-217F- 6 ~ F- 8
9400610065	101641-9143	WP-217D- 1 ~ D- 3	9460610332	104749-6971	WP-217F- 9
9400610067	101641-9190	WP-217D- 4 ~ D- 6			
9400610071	106671-2941	WP-217F-14 ~ F-15			
9400610073	101441-9161	WP-217B-11 ~ B-13			
9400610074	101441-9171	WP-217B-14 ~ B-16			
9400610075	101441-9420	WP-217C- 1 ~ C- 2			
9400610076	101441-9430	WP-217C- 3 ~ C- 4			
9400610077	101441-9490	WP-217C- 5 ~ C- 7			
9400610078	101441-9500	WP-217C- 8 ~ C-10			
9400610079	101342-0180	WP-217B- 1 ~ B- 2			
9400610080	101432-0160	WP-217B- 5 ~ B- 6			
9400610081	101601-6781	WP-217C-13 ~ C-14			
9400610084	106671-3252	WP-217G- 1 ~ G- 2			
9460610196	104749-2240	WP-217E-12 ~ E-13			
9460610213	104740-0201	WP-217D- 8			
9460610214	104748-0222	WP-217E- 1 ~ E- 2			
9460610216	104748-0051	WP-217D-15 ~ D-16			
9460610217	104749-3030	WP-217F- 1 ~ F- 3			
9460610230	104748-0242	WP-217E- 3 ~ E- 5			
9460610232	104769-2063	WP-217F-11 ~ F-13			
9460610250	104749-2260	WP-217E-14 ~ E-15			
9460610251	104740-4560	WP-217D-12			
9460610257	104748-2451	WP-217E- 9 ~ E-11			
9460610275	104740-3671	WP-217D- 9			
9460610276	104740-3681	WP-217D-10			
9460610277	104740-3691	WP-217D-11			
9460610320	104740-0102	WP-217D- 7			
9460610321	104761-4022	WP-217F-10			
9460610322	104749-3140	WP-217F- 4 ~ F- 5			